



**SM700 - series**  
**600 / 700 watts DC POWER SUPPLIES**



**SM 1540-D**

- \* 600 W
- \* 0 - 15 V 0- 40 A

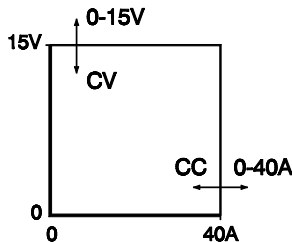

**SM 7020-D**

- \* 700 W
- \* **AUTORANGING**  
 0 - 35 V 0- 20 A  
 35-70 V 0- 10 A

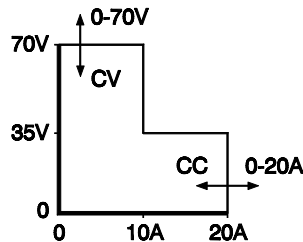

**SM 3004-D**

- \* 600 W
- \* **AUTORANGING**  
 0 - 150 V 0- 4 A  
 150-300 V 0- 2 A

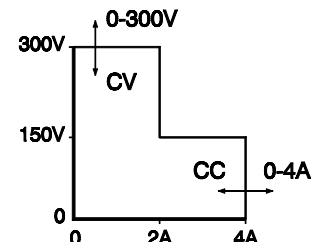

- Efficiency 90 %
- Weight only 7.4 kg
- 100 kHz MOSFET power conversion technique
- 0- 5 V analog programmable (voltage and current)
- Isolated analog programming with ISO AMP MODULE to prevent earth loops
- **IEEE 488** or **RS232** programming with external interface PSC 44M or PSC232 (pin compatible)
- Master / Slave parallel and series operation with equal current and voltage sharing
- Input / output insulation 3750 V rms
- Designed for long life at full power
- Voltage and current control with 10 turn potentiometers, resolution 0.03%
- Natural convection cooling, no blower, no noise
- 48 hours burn-in

	SM 1540-D	SM 7020-D	SM 3004-D
<b>Output</b>			
voltage range	0 - 15 V	0 - 70 V	0 - 300 V
current range	0 - 40 A	0 - 20 A	0 - 4 A
max. output power	600 W	700 W	600 W
AUTORANGING (2 ranges)	no	yes	yes
max. output <b>current</b> / volt. range	40 A / 0 - 15 V -	20 A / 0 - 35 V 10 A / 35 - 70 V	4 A / 0 - 150 V 2 A / 150 - 300 V
<b>Input</b>			
<b>AC input</b> , 48 - 62 Hz	90 - 132 V	95 - 132 V	95 - 132 V
110 V range	185 - 265 V	192 - 265 V	192 - 265 V
230 V range			
current (110 V AC)	8.4 A rms	9.6 A rms	8.3 A rms
current (230 V AC)	3.9 A rms	4.5 A rms	3.9 A rms
<b>DC input</b>	215 - 350 V	215 - 350 V	220 - 350 V
fuses	8 AT / 16 AT	8 AT / 16 AT	8 AT / 16 AT
standby input power ( $V_o=I_o=0$ )	7.5 W	7.5 W	7.5 W
standby input power ( $V_o=V_{max.}$ )	13.5 W	16.5 W	21.5 W
<b>Efficiency</b>			
DC input, full load	88 %	90 %	90 %
AC input, full load	87 %	89 %	88 %
<b>Regulation</b>			
Load 0 - 100% <b>CV</b>	5 mV	5 mV	20 mV
Line 192 - 265 V AC <b>CV</b>	5 mV	5 mV	20 mV
Load 0 - 100% <b>CC</b>	25 mA	12 mA	3 mA
Line 192 - 265 V AC <b>CC</b>	25 mA	12 mA	3 mA
<b>Ripple + noise</b>			
rms (BW=300kHz) <b>CV</b>	2 mV	3 mV	10 mV
pp (BW=50MHz) <b>CV</b>	10 mV	15 mV	50 mV
rms (BW=300kHz) <b>CC</b>	10 mA	5 mA	1 mA
pp (BW=50MHz) <b>CC</b>	25 mA	15 mA	3 mA
<b>Temp. coeff., per °C</b>	<b>CV</b> <b>CC</b>	$5 \cdot 10^{-5}$ $1 \cdot 10^{-4}$	
<b>Stability</b>			
during 8 hrs after 1hr warm-up and $t_{amb} = 25 \pm 1$ °C <b>CV</b>		$3 \cdot 10^{-4}$	
<b>CC</b>		$1 \cdot 10^{-3}$	

Analog Programming	CV	CC
<b>Programming inputs</b>		
input range	0 - 5 V	0 - 5 V
accuracy	$\pm 0.2\%$ + 0 mV ... + 8 mV (on 5 V)	$\pm 0.5\%$ + 0 mV ... + 20 mV (on 5 V)
temp. coeff. offset	10 $\mu$ V / °C	150 $\mu$ V / °C
input impedance	1 MOhm	1 MOhm
<b>Monitoring output</b>		
output range	0 - 5 V	0 - 5 V
accuracy	$\pm 0.2\%$ - 3 mV ... + 11 mV (on 5 V)	$\pm 0.5\%$ - 5 mV ... + 0 mV (on 5 V)
temp. coeff. offset	10 $\mu$ V / °C	150 $\mu$ V / °C
output impedance	20 Ohm	20 Ohm

<b>Reference voltage</b> on prog. connector $V_{ref}$ TC	$5.165 \pm 31$ mV typical 12 ppm / max. 30 ppm
<b>Status outputs</b> CC-status OVP / OVL-status	5V / 10 mA = logic 1 5V / 10 mA = logic 1
<b>Remote shutdown</b>	with + 5V or relay contact

Programming speed	SM 1540-D		SM 7020-D		SM 3004-D	
<b>programming UP</b> settling within output voltage step time, (100 % load) time, (10 % load)	50 mV 0 → 15 V 30 ms 30 ms	500 mV 0 → 15 V 18 ms 10 ms	50 mV 0 → 35 V 50 ms 50 ms	1 V 0 → 35 V 12 ms 12 ms	200 mV 0 → 150 V 50 ms 40 ms	5 V 0 → 150 V 14 ms 12 ms
output voltage step time, (100 % load) time, (10 % load)	- - -	- - -	0 → 70 V 100 ms 100 ms	0 → 70 V 40 ms 12 ms	0 → 300 V 100 ms 60 ms	0 → 300 V 60 ms 16 ms
<b>programming DOWN</b> settling within output voltage step time, (100 % load) time, (10 % load)	50 mV 15 → 0.5 V 30 ms 200 ms	500 mV 15 → 0.5 V 20 ms 200 ms	50 mV 35 → 2 V 50 ms 200 ms	1 V 35 → 2 V 10 ms 100 ms	200 mV 150 → 10 V 50 ms 180 ms	5 V 150 → 10 V 14 ms 120 ms
output voltage step time, (100 % load) time, (10 % load)	- - -	- - -	70 → 2 V 100 ms 800 ms	70 → 2 V 55 ms 120 ms	300 → 10 V 100 ms 800 ms	300 → 10 V 70 ms 700 ms
<b>Programming bandwidth</b> small signal large signal, 100 % load large signal, 10 % load	50 Hz 50 Hz 5 Hz		50 Hz 50 Hz 5 Hz		50 Hz 50 Hz 5 Hz	

	SM 1540-D	SM 7020-D	SM 3004-D
<b>Recovery time</b> recovery within di/dt of load step time, @ 50 - 100% load step max. deviation (high / low outp. range) @230VAC input, internal sensing	50 mV 4 A/μs 100 μs 200 mV	50 mV 2 A/μs 150 μs 80 / 150 mV	300 mV 0.5 A/μs 100 μs 450 / 900 mV
<b>Noise suppression</b> line - line ⇒ output line - earth ⇒ output	88 dB 88 dB	82 dB 88 dB	75 dB 75 dB
<b>Output impedance</b> CV, 0-100 kHz	< 40 mOhm	< 60 mOhm	< 700 mOhm
<b>Pulsating load</b> max. tolerable AC component of load current f > 1 kHz f < 1 kHz	10 A rms 40 A peak	5 A rms 20 / 10 A peak	1 A rms 4 / 2 A peak

<b>Insulation</b> input / output creepage / clearance	3750 Vrms (1 min.) 8 mm
input / case output / case	2500 Vrms (1 min.) 600 V DC
<b>Safety</b>	EN 60950 / EN 61010
<b>EMC</b>	<b>Emission</b> EN50081-1, EN55022B, EN61000-3-2, EN61000-3-3 <b>Immunity</b> EN50082-1, EN50082-2, EN61000-4-2-lv3, EN61000-4-4-lv4, ENV50140-lv3, ENV50141-lv3, ENV50204-lv3, EN61000-4-5-lv3-diff-mode-on-output, EN61000-4-5-lv2-comm-mode-on-output, EN61000-4-5-lv4-on-input, EN61000-4-11 (lv=level)
<b>Operating Temperature at full load</b>	- 20 to + 50 °C
<b>Humidity</b>	max. 95% RH, non condensing, up to 40 °C max. 75% RH, non condensing, up to 50 °C
<b>Storage temperature</b>	- 40 to + 85 °C
<b>Thermal protection</b>	Output shuts down in case of insufficient cooling
<b>MTBF</b>	500 000 hrs

<b>Hold-Up time</b> 100% load Vin = 230V AC 50% load Vin = 230V AC	20 ms 45 ms
<b>Turn on delay</b> after mains switch on	500 ms
<b>Inrush current</b>	6,5 A @ 230V AC input 30 A @ 110V AC input

	SM 1540-D	SM 7020-D	SM 3004-D
<b>Series operation</b> max. total voltage Master / Slave operation	600 V yes	600 V yes	600 V yes
<b>Parallel operation</b> max. total current Master / Slave operation	no limit yes	no limit yes	no limit yes
<b>Remote sensing</b> max. voltage drop per load lead	2 V => total voltage drop will subtract from max. available Vout		not available
<b>OVP / OVL</b> adjust range	0 - 17 V	0 - 80 V	0 - 350 V

<b>Potentiometers</b> front panel control with knobs resolution	standard 0.03 %	standard 0.03 %	standard 0.03 %
screwdriver adjustment at front panel at rear panel	option P001 option P002	option P001 option P002	option P001 option P002
<b>Meters</b> scale voltage scale current accuracy	3.5 digit 0 - 15.00 V 0 - 40.0 A 0.5% + 2 digits	3.5 digit 0 - 70.0V 0 - 20.0 A 0.5% + 2 digits	3.5 digit 0 - 300 V 0 - 4.00 A 0.5% + 2 digits

<b>Input Terminals</b> input connections	10 Amp / 65 °C Euro-connector at rear panel		
<b>Output Terminals</b> at rear panel	M8 bolts	6 mm bind post	4 mm bind post
<b>Programming connector</b>	15 pole D-connector at rear panel (FEMALE)		
<b>Cooling</b>	convection cooling		
<b>Enclosure</b> degree of protection	IP20		
<b>Dimensions</b> behind front panel (h x w x d) front panel (h x w)	89 x 428 x 257 mm (with option P099, feet are removed) 89 x 483 mm (19", 2 U)		
<b>Weight</b>	7.4 kg		

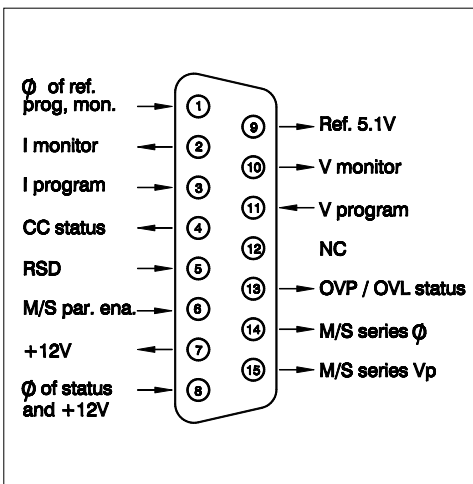

Connections programming connector

CV= Constant Voltage  
CC=Constant Current  
OVL=Over Voltage Limit=  
OVP=Over Voltage Protection

Specifications measured at  
t<sub>amb</sub> = 25 ± 5 °C and Vin = 230 V AC,  
50 Hz unless otherwise noted.

