

Ball bearing film thickness test rig

Film Thickness Measurement in Deep Groove Ball Bearings

Pramod Shetty*, Robert Jan Meijer, Jude Osara, Rihard Pasaribu and Piet Lugt

Working principle and schematic

- 1) Test bearing
- 2) Ceramic ball for axial loading
- 3) Axial load cell
- 4) Pneumatic bellow for axial loading
- 5) Hybrid support bearings
- 6) Rotation retainer
- 7) Mercury contact
- 8) Ceramic ball for the radial load
- 9) Pneumatic cylinder for radial load
- 10) Vibration isolator
- 11) Lock nut

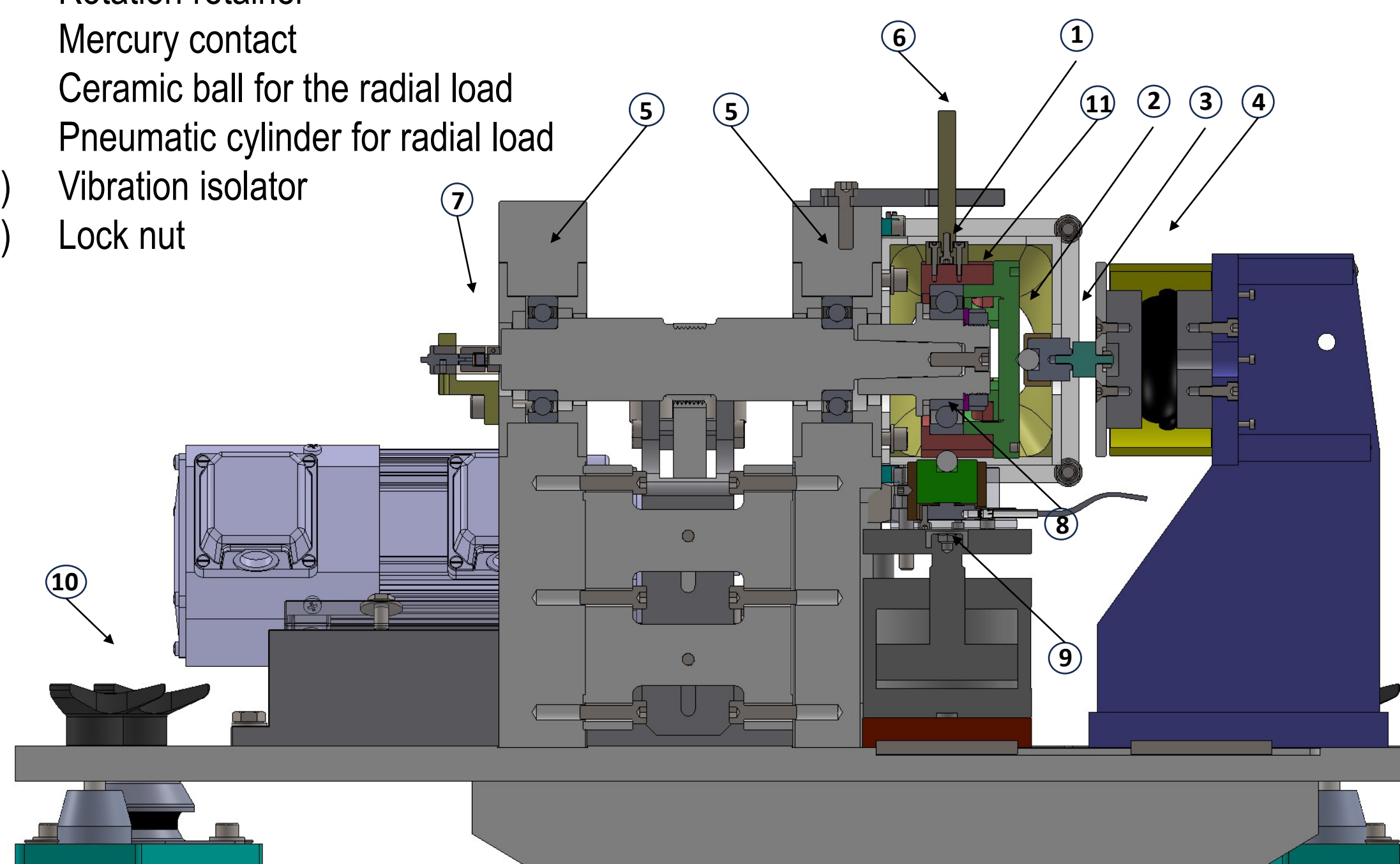

Sectional view of the test rig

This test rig employs the electrical capacitance method for film thickness measurement. It accommodates testing for three distinct bearing sizes, capable of reaching speeds of up to 15000 rpm. Additionally, it allows for the application of axial, radial, and combined loads.

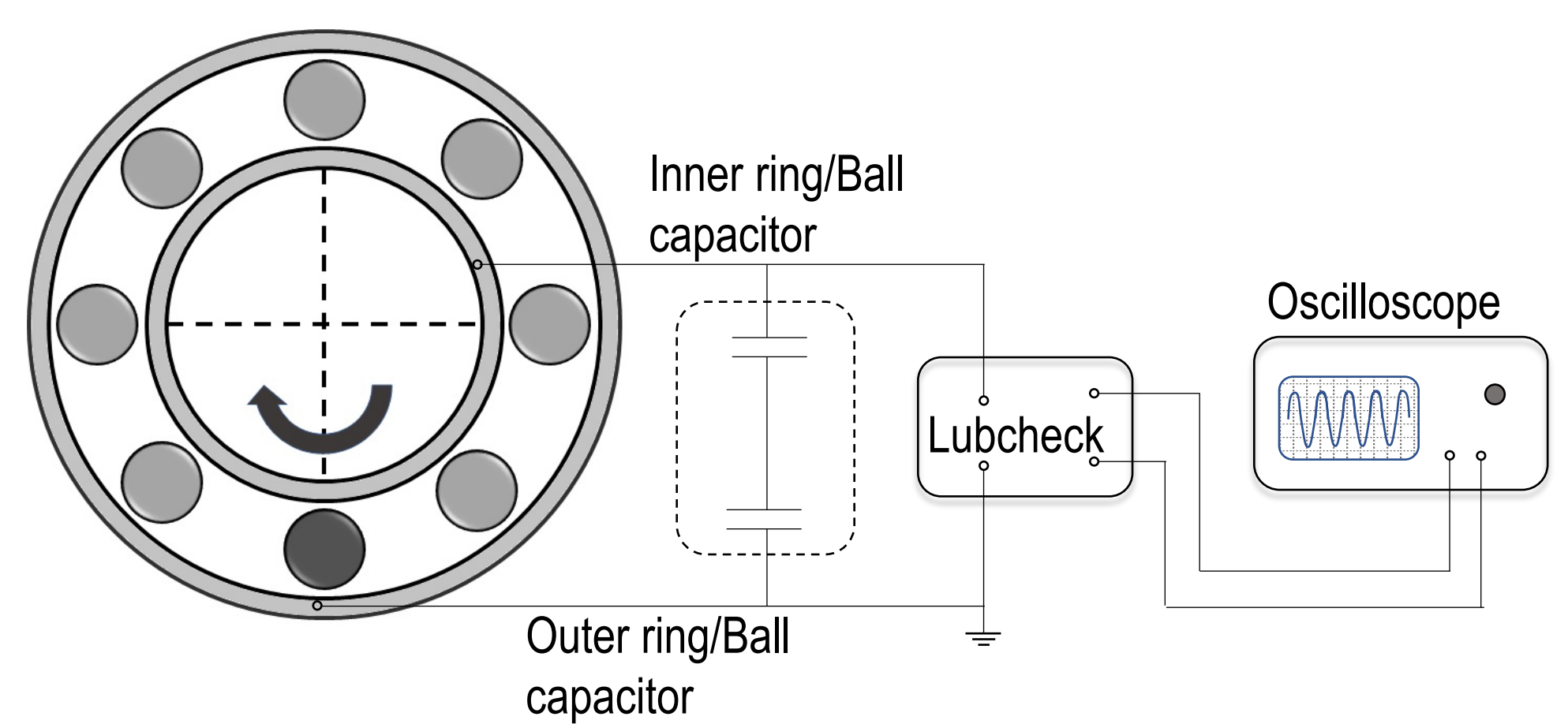

Schematic representation of the film thickness measurement interface on a single steel ball bearing using Lubcheck

Results and discussion

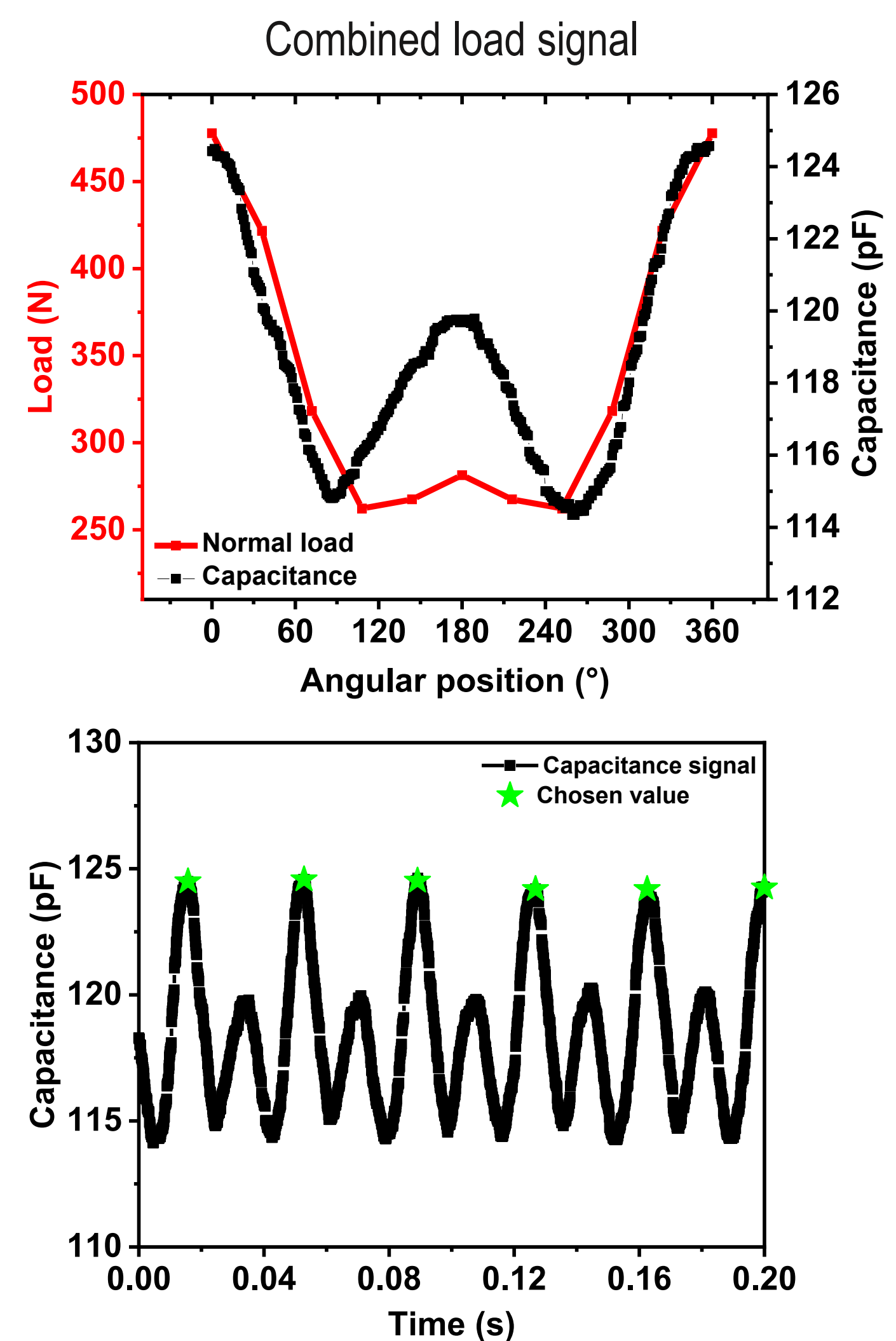
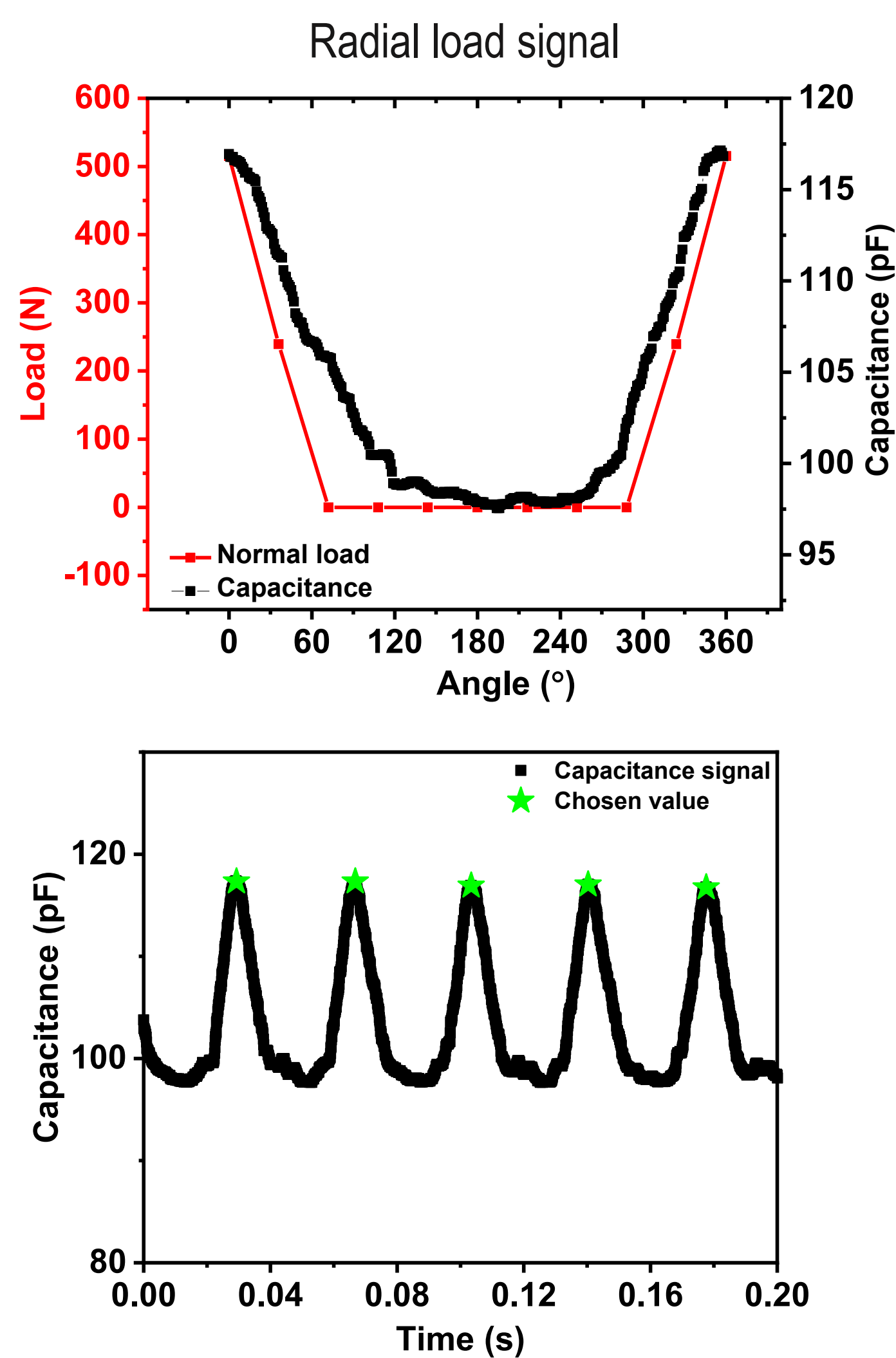

UNIVERSITY OF TWENTE.

Surface Technology and Tribology
Tribology based maintenance

P. Shetty*

p.shetty@utwente.nl