

# Electrically Variable Capacitance for the Tunable EMI Filter

## Bachelor thesis project

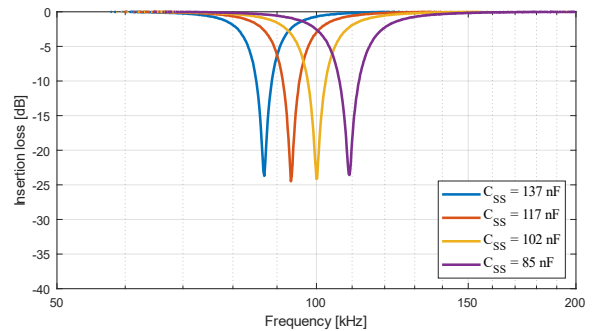
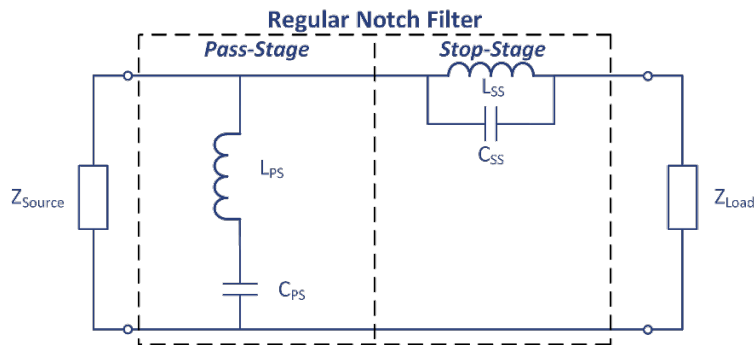

### Summary:

The aim of the project is to present a prototype of an electrically variable capacitor unit to be used as part of an adaptive notch filter for EMC applications.

### Problem definition:

The development of an electrically tunable capacitor unit for low-frequency and high-voltage applications will enable the realization of adaptive notch EMI filters. Most existing electrically tunable capacitors are designed for radio-communication systems, i.e. for high-frequency, low-voltage, and low-current applications. Thus, they are not suited for direct use as part of an electrically tunable notch EMI filter. However, in [1], a discrete electrically switchable capacitor is designed and proposed for use in the stop-stage of the notch filter. But the discrete capacitance variation results in an inability to tune to any frequency within the operation range. Alternatively, the continuous tuning voltage-controlled capacitance is presented in [2]. However, it is used as a part of a fixed frequency resonant power converter, but not a filter. Therefore, the question of its application as a part of an adaptive notch filter remains open. The effect of applying control bias voltage up to 100 V on the performance of the notch filter should be investigated, including testing the notch filter with this element.

### Method:

A literature review on the electrically variable capacitors and notch filter design. Based on the review and analysis, the appropriate approach is chosen and tested via simulations and measurements. The performance measurements of the notch filter with the designed unit should be conducted in the University of Twente laboratory.

### Research objectives:

- Comprehensive overview of the possible solutions for the electrically variable capacitance design.
- The design of the voltage-controlled capacitor and demonstrations of its performance as part of a tunable notch filter.

**\*Optional** - Development of software that would allow varying the capacitance value from a laptop or PC.

University of Twente.

# Electrically Variable Capacitance for the Tunable EMI Filter

## Bachelor thesis project

### Courses and supervision:

The general knowledge in the EMC field (non-ideal passive elements, EMI filters) will be helpful.

The skills in using laboratory equipment (e.g. spectrum analyzer, oscilloscope) are required.

A good affinity with LTSpice and MATLAB is very beneficial for doing this assignment.

### References:

[1] I. Struzhko, T. Hartman, F. Leferink, "Adaptive Notch Filter Based on Electrically Variable Components for EMC," submitted to EMC Europe 2024

[2] B. Guo, S. Dwari and S. Priya, "Voltage-Controlled Tunable Capacitor based Resonant Power Converter," 2019 IEEE Energy Conversion Congress and Exposition (ECCE), Baltimore, MD, USA, 2019, pp. 2164-2169, doi: 10.1109/ECCE.2019.8912954.

---

### Contact:

Ivan Struzhko ([Ivan.Struzhko@utwente.nl](mailto:Ivan.Struzhko@utwente.nl))

Tom Hartman ([Tom.Hartman@utwente.nl](mailto:Tom.Hartman@utwente.nl))

University of Twente.