

Renewable energy from mixing seawater and river water



David Vermaas

As fossil fuels slowly deplete and the power consumption increases, the need for affordable renewable energy sources grows. Renewable energy can be captured when mixing salt water and fresh water. Although this source of renewable energy is not applied yet at a large scale, the potential for such salinity gradient energy is huge. The global river water runoff – that flows unused into the sea at the moment – could theoretically produce enough electrical power to supply the full world of electricity ¹.

Salinity gradient energy can be captured in reverse electrodialysis (RED), in which ion exchange membranes are used for selective charge transport. The principle of reverse electrodialysis is explained in Fig. 1. The ions from the

these membranes. At the end of the membrane stack, the ionic current is converted into an electrical current at the electrodes (e.g. using a redox reaction), which can be used as a power source. As an alternative, capacitive electrodes can be used, to store ions and electrons, and therefore generate electricity without any redox reaction ².

Research focus

Although the technology for capturing salinity gradient energy was already presented in the 1950's ³, the technology was never applied on a large scale. The main obstacle was a low power production per membrane area in combination with a high membrane price. The power density was even more challenged when natural waters would be used, which could create fouling on the membrane surface. This research focuses on improving the power density (i.e. power per membrane area) altering the hydrodynamic conditions of a RED stack.

Intermembrane distance

To improve the obtained power density, the electrical resistance needs to reduce. The use of thin membrane and thin feed water compartments minimizes the ohmic electrical resistance. A thin feed water compartment, i.e. a small intermembrane distance, has additional benefits. The energy efficiency, i.e. the actual obtained energy relative to the theoretical energy released when the feed waters fully mix, is higher for small intermembrane distances ¹. Therefore, the highest power densities and energy efficiencies can be obtained using small intermembrane distances. This can be demonstrated by plotting the experimentally obtained power density and energy efficiency, for stacks with intermembrane distances of 60, 100, 200 and 485 μm , as is done in Fig. 2.

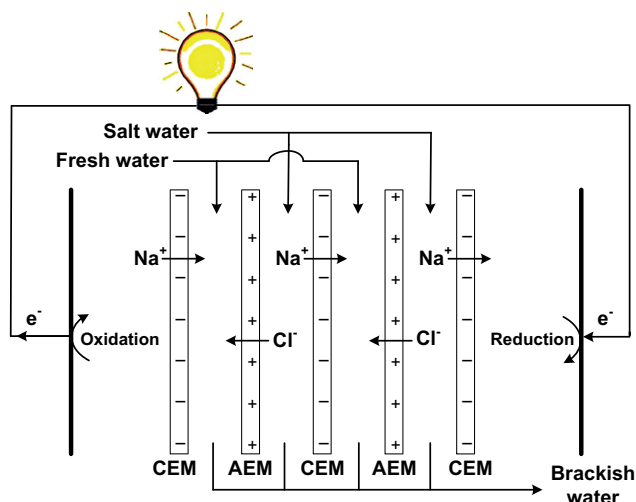

Figure 1 - Principle of reverse electrodialysis.

concentrated stream (e.g. seawater) are transported to the diluted stream (e.g. river water). The cations can only pass the cation exchange membranes (CEMs), while the anions can only pass the anion exchange membranes (AEMs). This selective transport creates a voltage over each membrane, as defined by the Nernst equation. Several membranes can be stacked to cumulate the voltage, with alternately seawater and river water in the compartments between

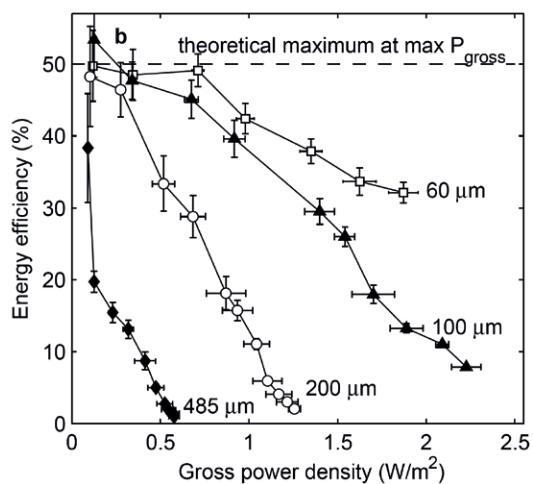

Figure 2 - Energy efficiency versus gross power density, for stacks with different intermembrane distances (60, 100, 200 and 485 μm)¹.

Although the power density and energy efficiency are most promising for very small intermembrane distances (Fig. 2), this is not a practical operational mode. The power consumed on pumping the feed water increases rapidly as the intermembrane distance decreases. Therefore, the net power density, which is corrected for the power consumed for pumping the feed waters, is optimum for an intermembrane distance of 100 micrometer¹.

Profiled membranes

For further improvement of the (net) power density, a spacerless system is required. The spacer significantly increase the power spent on pumping, and the non-conductive spacers induce a large electrical resistance. These spacers cover a part of the membranes, referred as the spacer shadow effect, such that less membrane area is available for ion exchange. Ion conductive spacers, made from membrane material, already proof to reduce the ohmic resistance by almost a factor 4⁴. However, the non-ohmic resistance, due to the diffusive boundary layers, increased and limited the power density.

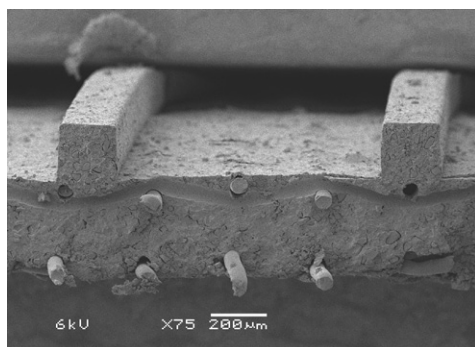

Figure 3 - Profiled membrane, in this case a CEM, created by hot pressing a thermoplastic membrane into a mould⁵.

Integrating the (conductive) spacer functionality with the membrane was the next step, which resulted in a membrane

with ion conductive profiles (i.e. corrugations) on its surface to create channels for the feed water⁵. Fig. 3 shows such a profiled membrane.

With profiled membranes, ions are no longer limited by the spacer shadow effect. Moreover, the power consumed for pumping the feed water is much smaller than when a stack with spacers is used. The net power density is thus higher for designs with profiled membranes compared to designs with spacers⁵ (Fig 4). The difference in net power density is still moderate due to the thick membranes that are used in this research and the unequal water distribution over the feed water compartments. The difference will be amplified when thinner, profiled, membranes would be used and thinner compartments would be used. An important advantage of the profiled membranes is that this design can be used over a larger range in Reynolds number (i.e. less sensitive to Reynolds number, as shown in Fig. 4), whereas the design with spacers has a more limited range for optimization⁶.

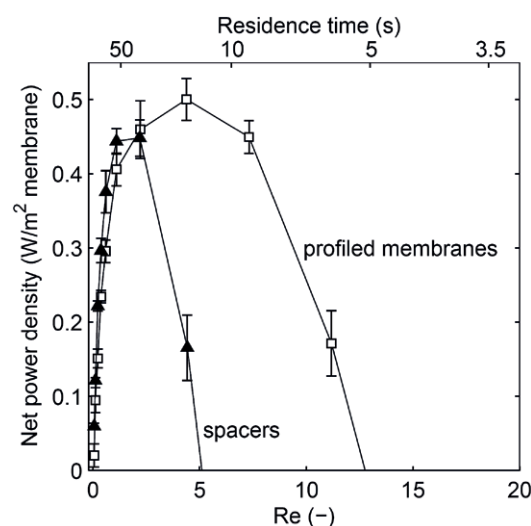

Figure 4 - Net power density, obtained from stacks with spacers and stacks with profiled membranes⁵.

Fouling

For a large-scale power plant, natural river water and seawater can be applied. Due to the large quantities of water required for such a power plant, and the low price of electricity from other (conventional) electricity sources, these natural feed waters cannot be cleaned thoroughly. Therefore, the RED stack may get fouled. A first fouling test is performed to examine what fouling type will develop if no anti-fouling treatment (other than course filtering) is applied. This was applied for stacks with flat membranes and spacers, as well as for stacks with profiled membranes⁷. Scanning Electron Microscope (SEM) images of these fouling types, after 25 days of operation with natural feed water, are shown in Fig. 5.

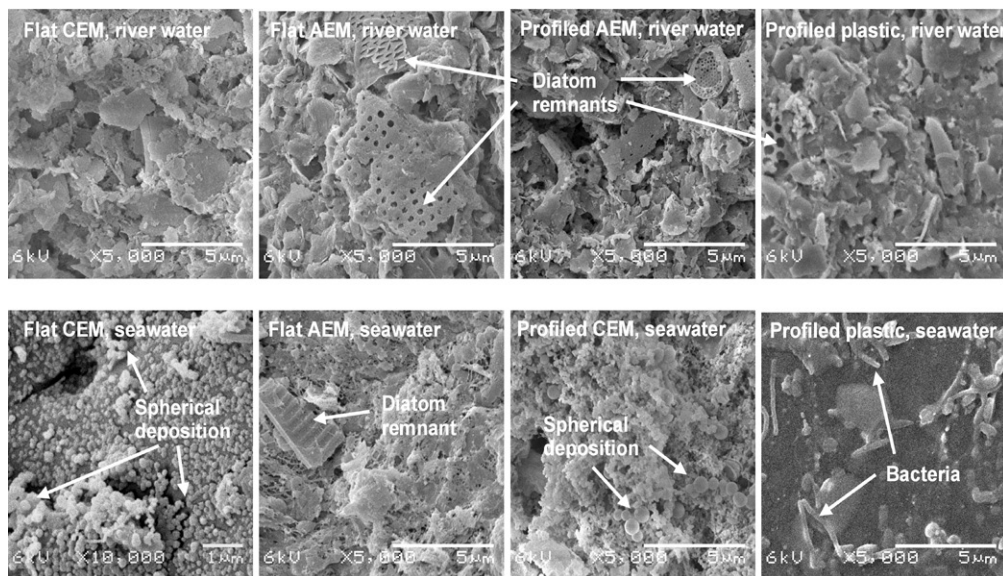

Figure 5 - SEM-images for samples from a stack with flat membranes and spacers and from a stack with profiled membranes⁷.

As Fig. 5 shows, the main fouling types are diatom remnants, some scaling (spherical deposition) and different types of clay particles. This colloidal fouling and scaling causes an increase in pressure drop for pumping the feed water through the compartments. This is also demonstrated in Fig. 6, which shows the pressure drop over the river water feed compartment for stacks with spacers and stacks with profiled membranes for 25 days of operation in natural water.

Fig. 6 shows that the stack with spacers reaches a pressure drop of approximately 1700 mbar in 5 days, which is the maximum pressure that can be generated by the feed water

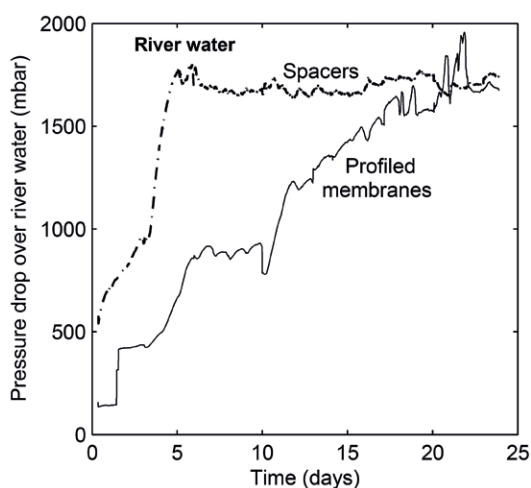

Figure 6 - Pressure drop over river water feed, for stacks with spacers and profiled membranes, all running on natural seawater and river water for 25 days⁷.

pumps. From this moment, the flow rate for the stack with spacers reduced. The colloids are trapped in the small openings and dead zones in the spacer filled channels. The stack with profiled membranes reached the maximum pressure drop in approximately 20 days, i.e. the increase in pressure drop is 4 times slower for a stack with profiled

membranes compared to a similar stack with spacers. In addition, a RED design appeared to be more sensitive to small fluctuations in the flow (e.g. between day 10 and 11)⁷. This opens the opportunity to remove fouling in stacks with profiled membranes using periodical flow fluctuations as anti-fouling treatment.

The obtained power density from a stack with profiled membranes remained higher than that in a stack with spacers, while the pressure drop remained lower⁷.

Outlook

The changes in the flow field, in this case using profiled membranes, improve the obtained power density in laboratory conditions and under practical natural conditions. A pilot facility is being built at the Afsluitdijk (The Netherlands), where seawater and river water can be used in practice to generate electricity. The improvements in power density and fouling prevention, derived from the present scientific research, will be applied in this facility to generate renewable energy from salinity gradients on a large scale.

For more information about this work, please contact Prof. Dr. Ir. Kitty Nijmeijer (d.c.nijmeijer@utwente.nl; phone: +31 (0)53 489 4185).

References

1. Vermaas, D. A.; Saakes, M.; Nijmeijer, K., Double Power Densities from Salinity Gradients at Reduced Intermembrane Distance. *Environmental Science & Technology* 2011, 45, (16), 7089-7095.
2. Vermaas, D. A.; Bajracharya, S.; Sales, B. B.; Saakes, M.; Hamelers, B.; Nijmeijer, K., Clean energy generation using capacitive electrodes in reverse electro dialysis. *Energy & Environmental Science* 2013, 6, (2), 643-651.
3. Pattle, R. E., Production of Electric Power by mixing Fresh and Salt Water in the Hydroelectric Pile. *Nature* 1954, 174, (4431), 660-660.
4. Długotęcki, P. E.; Dąbrowska, J.; Nijmeijer, K.; Wessling, M., Ion conductive spacers for increased power generation in reverse electro dialysis *Journal of Membrane Science* 2010, 347, (1-2), 101-107.
5. Vermaas, D. A.; Saakes, M.; Nijmeijer, K., Power generation using profiled membranes in reverse electro dialysis. *Journal of Membrane Science* 2011, 385-386, (0), 234-242.
6. Vermaas, D. A.; Guler, E.; Saakes, M.; Nijmeijer, K., Theoretical power density from salinity gradients using reverse electro dialysis. *Energy Procedia* 2012, 20, 170-184.
7. Vermaas, D. A.; Kunteng, D.; Saakes, M.; Nijmeijer, K., Fouling in reverse electro dialysis under natural conditions. *Water Research* 2013, 47, (3), 1289-1298.

Characterisation of gas and vapor separation membranes

Introduction

Selective gas permeation through non-porous materials is based on the difference in solubility and diffusivity of gasses through a given membrane and is generally described by the “solution-diffusion” model, equation 1.

$$P_i = D_i \times S_i \quad [1]$$

where:

P = permeability coefficient ($\text{cm}^3 \text{ cm/cm}^2 \text{ s Pa}$)

S = solubility coefficient ($\text{cm}^3(\text{STP})/(\text{cm}^3 \text{ Pa})$)

D = diffusion coefficient (cm^2/s)

The ideal selectivity, α , of a gas pair is the ratio of their individual permeability coefficients, equation 2.

$$\alpha_{ij} = \frac{P_i}{P_j} = \left(\frac{D_i}{D_j} \right) \times \left(\frac{S_i}{S_j} \right) \quad [2]$$

In general the diffusion coefficient decreases with decreasing penetrant size increasing polymeric fractional free volume, increasing polymer chain flexibility, increasing temperature and decreasing polymer penetrant interactions. On the other hand, solubility coefficient increases with increasing polymer penetrant interactions, decreasing temperature and increasing condensability of the penetrant¹.

At the Membrane Technology Group we have an extensive range of equipment available to determine sorption isotherms for both gasses and vapors and to determine the permeability coefficient for single components as well for mixtures. This allows us to make a full description of the membrane solution-diffusion behavior. In this overview we place a view characterization techniques in the spotlight that helps you in better understanding the vapor and gas permeation properties of your membranes.

Gas Sorption - Magnetic Suspension Balance

The technique of weighing is one of the most accurate measuring methods for experimental investigations. For numerous applications, however, it is not possible or useful to locate a balance or a weighing instrument in the measuring chamber itself (e.g. at high temperatures, high pressures, aggressive atmospheres). In many of these cases a magnetic suspension balances can be a suitable solution.

High accuracies can be reached, as the microbalance is

separated from the sample and measuring atmosphere.

An electromagnet -permanent magnet pair transmits the mass change of the sample in the measuring cell through the wall of the pressure vessel.

The operational window is vacuum $< p < 80$ bars,

$20^\circ\text{C} < T < 90^\circ\text{C}$.



Magnetic suspension balance

In our laboratory we use for the determination of the gas sorption a Rubotherm® magnetic suspension balance. The recorded weight has to be corrected for buoyancy effects according to the Archimedes principle. This is done by subtracting the weight as determined at zero sorption at a certain pressure from the vacuum weight of the sample. The density of the sample is determined at room temperature using a helium pycnometer, AccuPyc II 1340. The corrected equilibrium weight increase and the density of the polymer allow calculating the solubility and solubility coefficient. The corrected mass uptake of the sample (m_t) can be calculated according to Equation. 3:

$$m_t = w_t - (w_0 - V_t \times \rho_{gas}) \quad [3]$$

where:

w_t = weight (g) of the sample at time t (s)

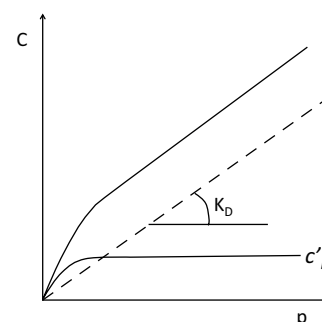

Figure 1 - Dual mode sorption model.

w_0 = the weight of the sample (g) at zero sorption,

V_t = the volume (cm^3) of the sample at time t (s)

ρ_{gas} = the density of the gas (g/cm^3).

The sorption measurements are used to construct sorption isotherms in order to determine capacity and affinity constants for various samples. The sorbed amount of pure gas as function of the pressure is presented by the dual mode

sorption model based on Henry's law and the Langmuir model, and can be written as:

$$C = k_D \times p + \frac{C_h \times b \times p}{1 + b \times p} \quad [4]$$

where k_D (the Henry's law constant) which is equal to the solubility coefficient S , C_h (the saturation constant) and b (the hole affinity constant) are the pure component values. These constants can be calculated from the measured sorption data.

Water Vapor Sorption Balance

For determining the sample water vapor uptake we make use of a Symmetrical Gravimetric Analyzer, SGA-100 (VTI). Water vapor isotherms are allowed to measure at temperatures ranging from 0 °C to 80 °C at ambient pressure.



Vapor sorption equipment, SGA100, the bar indicates the 3 thermal zones.

The term symmetrical refers to a design feature

whereby both the sample side and the reference side of the microbalance are subjected to identical temperatures, relative humidity & flow rates. Other benefits are related to the symmetrical design that allow absolute or differential adsorption experiments. In addition to isotherms, isohumes, maintaining constant humidity and equilibrating the sample to a series of temperatures, heats and kinetics of adsorption, hydrate formation can also be studied. The core of the instrument is an isothermal aluminum block containing the sample chamber, which permits very tight control of temperature and RH at the sample. Chilled-mirror dew point analyzers are used to determine the actual humidity. And three isolated thermal zones are ensuring operational stability. The temperature within the block is kept stable by a constant temperature bath capable of temperature control within 0.01°C. The water uptake of the (polymer) sample, c in (cm³(STP)/cm³ polymer), is calculated using the equilibrium mass uptake m_∞ in (g) at certain water activity or temperature according to equation 5. V_{H_2O} is the volume of 1 mol H₂O (STW cm³)

$$C = \frac{(M_\infty - M_{polymer,dry}) \times V_{H_2O}}{V_{polymer,dry} \times M_{w,H_2O}} \quad [5]$$

Specifications

- Temperatures from 5 to 80°C with optional sample drying to 250°C
- Relative Humidity from 2% to 98%RH
- Real-time humidity and temperature measurements allow for precise control to within ±1.0 %RH and ±0.1°C using a Dew Point Analyzer and temperature control system.
- Precision microbalances available with resolutions down to 0.1 µg; max sample weight 750 mg; dynamic range 100 mg.

Water vapor sorption isotherm

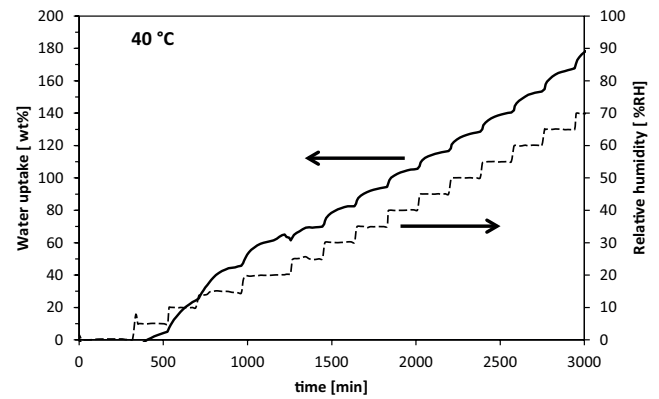

Figure 2 - Example of a water vapor sorption isotherm.

Gas and vapor permeation

For the determination of gas permeation properties of both flat sheet and hollow fiber membranes we have several setups available. Depending on the desired gas, single or mixed gas, pressure, temperature and the presence of water vapor we select the appropriate setup. At our laboratory



Gas permeation cell for hollow fibers, to control the temperature the cell is double walled.

we are capable to measure single gas and mixed gasses from 0 to 80 bars and from 0 to 80°C. The permeance, P/l , of pure gases through the membranes is calculated from the steady state pressure increase with time in a calibrated volume on the permeate side. The permselectivity coefficient is defined by the ratio of pure gas permeances while the effective skin layer thickness will be calculated by dividing the intrinsic gas permeability with the obtained permeance value.

To evaluate the mixed gas selectivity the composition of both

feed and permeate is determined by gas chromatographs. The associated total gas permeance is measured as described



One of the high-pressure mixed gas separation equipments, in the flat sheet configuration. In case of mixed gas measurements a gas chromatograph analyzes the feed and permeate concentrations.

above for single gas permeation. When apart from gasses also water vapor is present we have the availability of a setup that make use of dew points meters to quantify the water vapor amount in the feed and permeate streams before analyzing the gas composition.

Since we make use of premix gasses we are able simulate several commercial processes. Due to safety regulations we are not allowed to use e.g. H_2S and CO yet.

Reference

[1] J. Ploegmakers et al., Mixed matrix membranes containing MOF's for ethylene/ethane separation. Part A: Membrane preparation and characterization, *Journal of Membrane Science*, 428, 2013, 445-453.

Award

COTOO project wins WEX award in Madrid

At the recently held Water and Energy Exchange Global 2013 conference in Madrid, Spain, Dutch water supply company Vitens NV was awarded the global 'Innovation in Process Technology' award by the WEX. Vitens received the award for their Clean Operator concept, investigated in the InnoWATOR COTOO project together with the Membrane Science and Technology Group at the University of Twente, RWB Waterservices and WE Consult.

Clean Operator is a revolutionary new and sustainable concept for cleaning spiral wound membrane modules. During cleaning no chemicals are used, and it easily can be incorporated in existing installations with horizontal membrane modules in series. The concept firstly was proven on lab scale at the University of Twente by MST researchers Ikenna Ngene [1] and Abdulsalam Al-hadidi. Instead of using chemicals, the method involved the use of water saturated with dissolved CO_2 at higher pressures followed by a hydraulic rinsing of the fouled membrane/spacer channel at a lower pressure. At locations where the channel is fouled, depressurization occurs which causes bubble nucleation at the spacer filaments (Figure 1), and a very efficient cleaning of the membrane module.

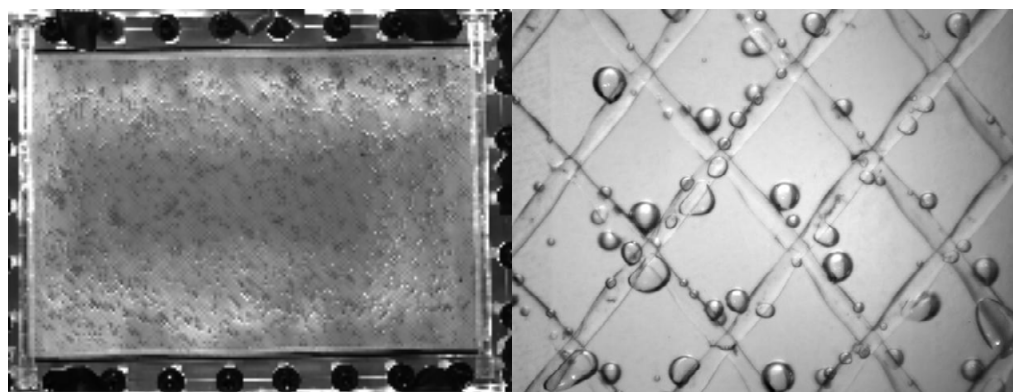

Figure 1 - CO_2 nucleation on the feed spacer of spacer filled RO membrane channel (flow direction right to left, cell orientation 90°)

Long term pilot tests at the Noardburgum location of Vitens demonstrated this technology to be as effective as the often applied CIP. However, it has the advantage of being cheaper, less sensitive and less chemically intensive. Pre-treatment can be simplified, implying capital costs for new plants can be lower as well as operational costs for new as well as existing plants. More information: Dr.ir. Antoine Kemperman, a.j.b.kemperman@utwente.nl, tel. +31-53-4892956.

Reference

[1] I.S. Ngene, R.G.H. Lammertink, A.J.B. Kemperman, W.J.C. van de Ven, L.P. Wessels, M. Wessling, et al., CO_2 Nucleation in Membrane Spacer Channels Remove Biofilms and Fouling Deposits, *Ind. Eng. Chem. Res.* 49 (2010) 10034–10039.

Membranes for ethylene/ethane separation



Jeroen Ploegmakers

Ethylene is the single largest produced chemical. However, due to their almost similar boiling points, both ethylene and ethane, culminate in the product stream after the cracking process of naphtha. Since ethane can only be used as feed for the steam-cracker, separation of these components is required. Currently, ethylene/ethane separation is carried out by cryogenic distillation at 248 K and 2.2 MPa, consuming large amounts of energy. Hybrid membrane-distillation plants could be a viable alternative to reduce the current energy consumption. However, the best performing membranes reported for the binary ethylene/ethane separation, are not yet sufficient to be economical viable. Also, at feed pressures of 2.2 MPa, polymer membranes can show plasticization phenomena, which is associated with a loss in selectivity, complicating the implementation of membranes even further.

Scope of the project

The first goal of this study was to perform an economical evaluation to assess the ethylene/ethane selectivity and ethylene permeance required to obtain economical savings in a hybrid membrane-distillation plant. The second goal was to investigate sorption and swelling behavior of thin polymer films. As membranes become increasingly thinner to enhance their permeance, a thorough investigation on the effect of ethylene and ethane on thin polymer films is required. Finally, the concept of mixed matrix membranes was applied to enhance the performance of polymer membrane.

Economical evaluation

A hybrid membrane-distillation plant was modeled using Honeywell's Unisim Design Suite and its performance was compared to as conventional cryogenic distillation plant [1]. Three difference hybrid configurations were evaluated, i.e. a 1500 kmol/hr parallel, 1500 kmol/hr series and 2500 kmol/hr series configuration. The parallel configuration is shown in Figure 1 and features a side stream drawn from the column, which feeds the membrane module. The stage number from which the side draw is drawn, is flexible. In this way, the ethylene concentration fed to the membrane module can be optimized. The drawback of this configuration is that the

maximum flow of the side draw has to be limited to avoid hydrodynamic disturbances. In this study, the side draw was limited to 1500 kmol/hr, which corresponds to 20% of the vapor flow inside the rectifying section of the column. Figure 2 shows the series configuration of a hybrid

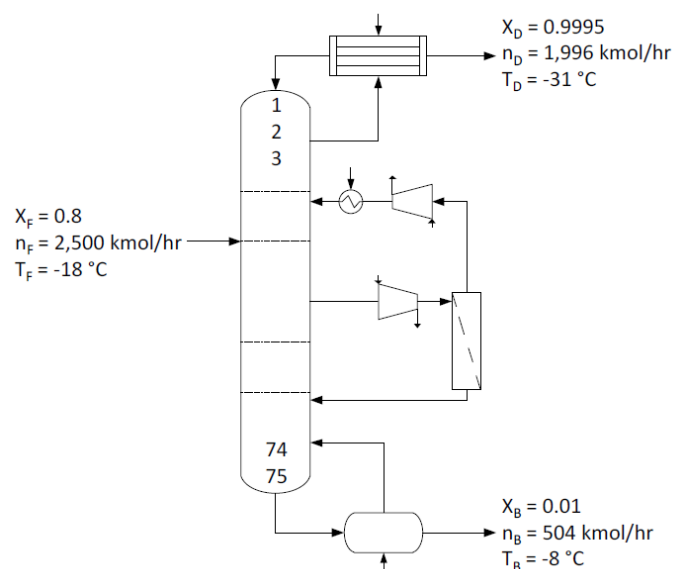

Figure 1 - Hybrid membrane-distillation plant in parallel configuration.

membrane-distillation plant. In this configuration, the feed stream first enters the membrane. Both the permeate and the retentate are subsequently fed to the distillation column. The drawback of this configuration is the fixed ethylene/ethane composition, which was set to 80/20 (mol/mol). However, unlike the parallel configuration, the maximum flow that can be fed to the membrane module was not limited to 1500 kmol/hr. Therefore, two series configurations were investigated. In the first configuration, the membrane feed flow was set a 1500 kmol/hr and the remaining 1000 kmol/hr was directly fed to the column. This allowed for a fair performance comparison with the parallel configuration. In the second series configuration, the feed flow to the membrane was set at the maximum flow of 2500 kmol/hr. No significant difference was found between the parallel and the series configuration. However, unlike the parallel configuration, which was limited to 1500 kmol/hr, the membrane feed in the series configuration could be increased

to 2500 kmol/hr, yielding additional savings. Afterwards, the selectivity and ethylene permeance were varies, as well as process conditions like the membrane feed and permeate pressure and the membrane area.

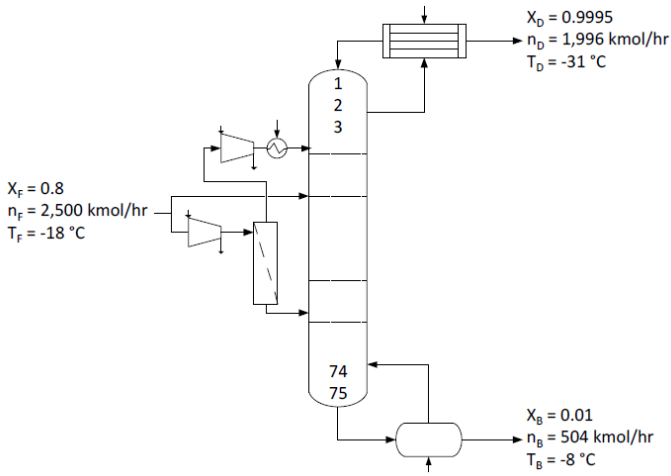

Figure 2 - Hybrid membrane-distillation plant in series configuration.

Figure 3 shows the savings that can be obtained after optimization as function of the ethylene permeance, for membranes with a selectivity of 30, 100 and 300. To obtain net savings, a minimum selectivity of 30 is required. Although

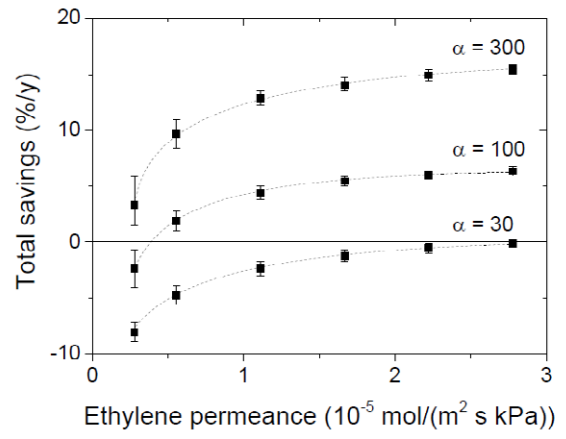

Figure 3 - Total savings (%/y) as function of ethylene permeance for membranes with a selectivity of 30, 100 and 300 in a 2 500 kmol/hr series configuration. Membrane feed pressure = 4 850 kPa, membrane permeate pressure = 2 050 kPa and membrane area = 10 000 m².

some literature reports higher selective membranes, this is often achieved by facilitated transport membranes, which suffer from stability issues due to carrier poisoning and leaching. The ethylene permeance required at this selectivity is $2.8 \cdot 10^{-5} \text{ mol}/(\text{m}^2 \text{ s kPa})$, which translates to $2.8 \cdot 10^{-14} \text{ kmol}/(\text{m}^2 \text{ s kPa})$ ($= 0.8 \text{ Barrer}$) assuming $1 \mu\text{m}$ thick membranes. This should be a realistic value to achieve, as many commercial polymers already possess such permeabilities.

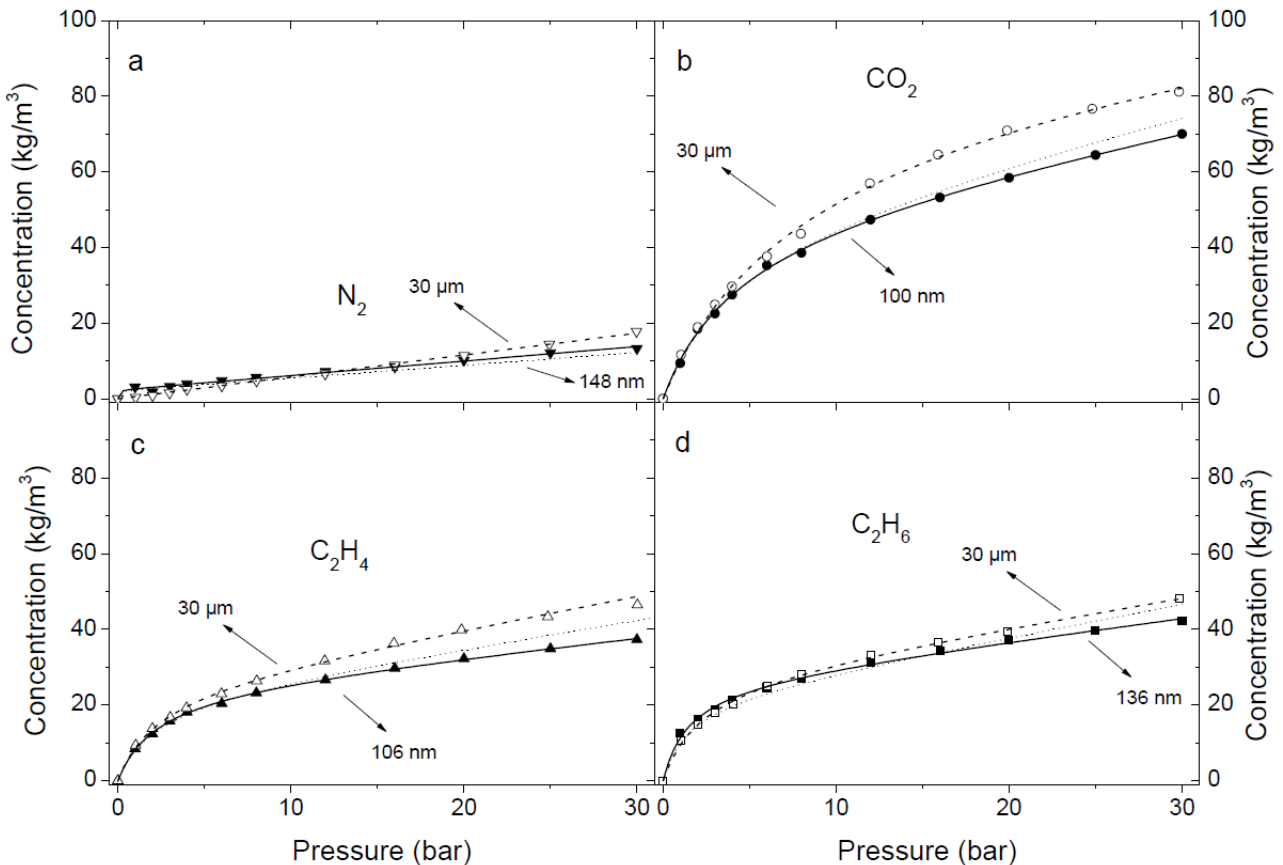

Figure 4 - Concentration of (a) N_2 , (b) CO_2 , (c) C_2H_4 and (d) C_2H_6 in thin (solid) and bulk (dashed) PPO films as function of pressure.

Sorption and swelling in thin PPO films

As membranes become increasingly thinner to enhance the flux, questions arise regarding the effect of membrane thickness (i.e. thin (≤ 100 nm) and bulk (≥ 1 μm)) on polymer properties. It has been frequently reported that thin films show accelerated physical aging, losing fractional free volume and Langmuir sorption sites when exposed to CO_2 . However, no reports exist on the effect of ethylene and ethane on thin films and whether their influence is comparable to that of CO_2 . Therefore, thin and bulk films have been exposed to different penetrants (i.e. N_2 , CO_2 , C_2H_4 and C_2H_6) and the difference in sorbed concentrations is shown in Figure 4. CO_2 sorbed in significant higher concentrations in PPO as compared to N_2 , due to additional Langmuir sorption. However, due to the accelerated physical aging in thin films and the associated loss in Langmuir sites, a reduction in CO_2 Langmuir sorption can be observed in Figure 4b. Similar behavior can be seen for ethylene and ethane in Figures 4c and 4d, where sorption in thin films is consequently lower as compared to sorption in bulk films. This indicates that exposure of thin glassy membranes to ethylene and ethane can cause similar unwanted behavior such as plasticization and accelerated physical aging.

Mixed matrix membranes containing metal-organic frame works

Since the ethylene/ethane selectivity of the best performing glassy polymer membranes is still too low to be economically viable, steps to increase this selectivity have to be taken.



Figure 5 - Mixed matrix membranes (MMMs) containing various MOFs, used in this study. From left to right: Native P84, P84 + 10% Cu_3BTC_2 , P84 + 20% Cu_3BTC_2 , P84 + 40% Cu_3BTC_2 , P84 + 20% FeBTC and P84 + 20% MIL-53 (Al).

Metal-organic frameworks (MOFs) have already shown to enhance the selectivity for other gas pairs by selective

complex formation of the fast permeating compound. In this part of the research, Cu_3BTC_2 , FeBTC and MIL-53 (Al) MOFs were added to a the polyimide P84[®] and the prepared membranes are shown in Figure 5 [2].

Cross-sectional SEM images of the 20 w% Cu_3BTC_2 , FeBTC and MIL-53 (Al) MMMs are shown in Figure 6. During the solvent evaporation step, the MOFs descended to the bottom of the membrane because of their higher density as compared to the polymer. This led to the formation of asymmetric membranes as is visible in Figure 6a. However, as will be discussed later, this inhomogeneous distribution of the MOFs did not affect the separation performance in a negative way.

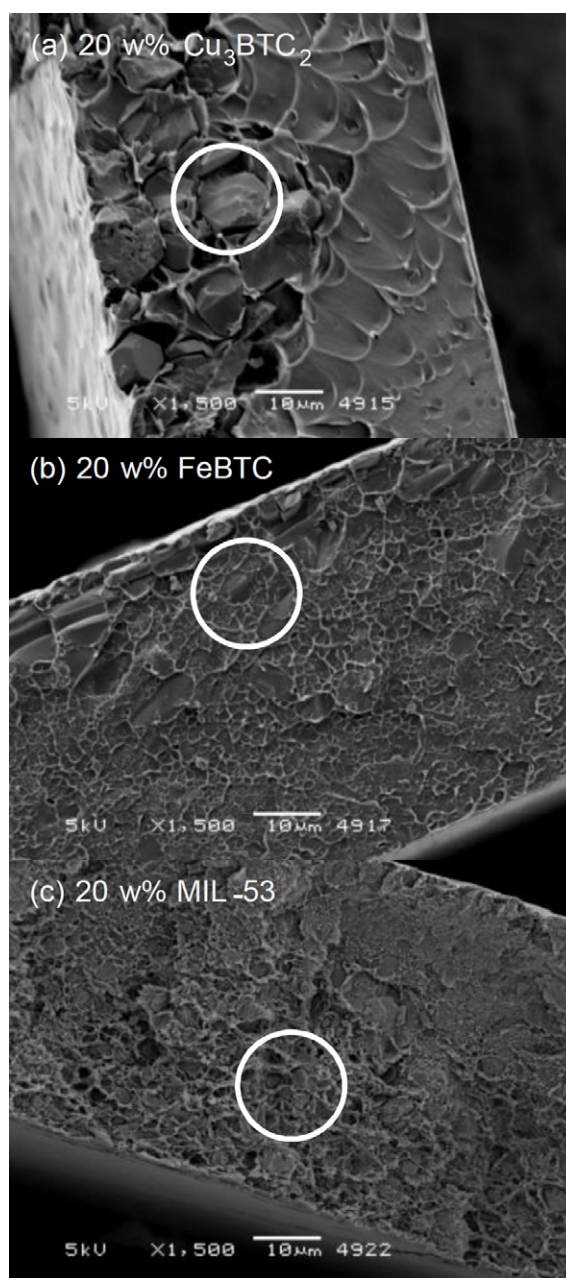

Figure 6 - SEM images of P84 MMMs with (a) 20 w% Cu_3BTC_2 (b) 20 w% FeBTC and (c) 20 w% MIL-53. Particles are indicated by a white circle.

The best performing MOF proved to be Cu_3BTC_2 , as shown in Figure 7, due to the ethylene- Cu^{2+} interaction that enhanced

the solubility in the mixed matrix membranes (MMMs). Addition of 20 w% Cu_3BTC_2 increased the selectivity as opposed to addition of FeBTC or MIL-53 (Al). Addition of MIL-53 (Al) did yield a significant permeability increase, but this was the result of non-selective voids between the MOF particles and the polymer matrix. The effect of Cu_3BTC_2 was further investigated by varying its concentration in the polymer matrix and this is shown in Figure 8 [3].

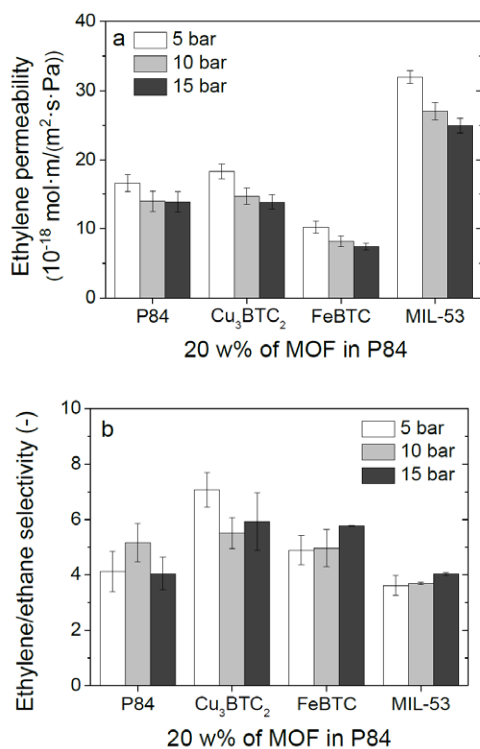

Figure 7 - (a) Ethylene permeability and (b) ethylene/ethane selectivity for native P84 membranes and MMMs with 20 w% Cu_3BTC_2 , FeBTC and MIL-53 (Al).

The ethylene permeability does not change with increasing Cu_3BTC_2 loading up to 20 w%, while simultaneously, the selectivity increases 71%. At higher loadings, non-selective voids appear in the MMMs, causing increased ethylene permeabilities and reduced selectivities close to that of the native polymer. Sorption experiments reveal that increased concentrations of Cu_3BTC_2 in the matrix lead to an increase in both solubility and diffusion coefficients. This implies that the increased affinity of ethylene towards Cu_3BTC_2

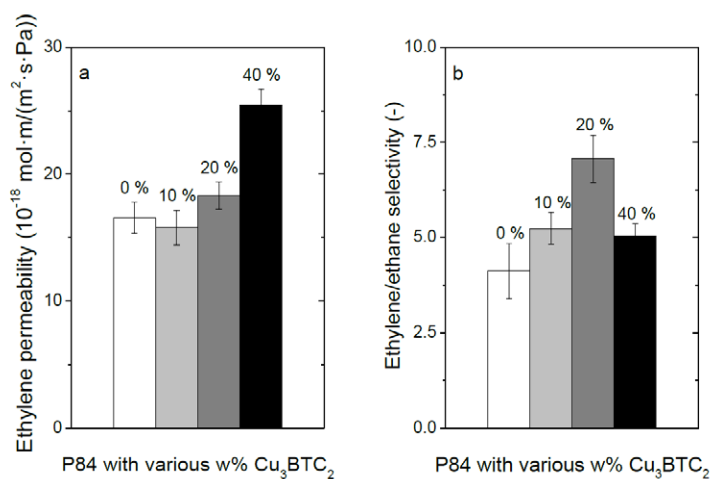

Figure 8 - (a) Ethylene permeability and (b) ethylene/ethane selectivity as function of Cu_3BTC_2 loading.

MMMs, leads to higher diffusion coefficients for sorption into the membranes. However, there is a decreased diffusion coefficient at the desorption stage as evidenced by the constant remaining ethylene permeability. Therefore, there appears to be a subtle balance between weak MOF-penetrant interactions that increase the permeability, and strong MOF-penetrant interactions that increase the selectivity, which should be taken in to account in future research towards novel MOFs for gas separations.

The public defense of this work is expected to take place at the end of 2013.

For more information about these topics, please contact Prof. Dr. Ir. Kitty Nijmeijer (d.c.nijmeijer@utwente.nl; phone: +31 (0)53 489 4185).

References

- [1] J. Ploegmakers et al., Economic evaluation of membrane potential for ethylene/ethane separation in a retrofitted hybrid membrane-distillation plant using UniSim[®] Design, Industrial & Engineering Chemistry Research, DOI: <http://dx.doi.org/10.1021/ie400737s>.
- [2] J. Ploegmakers et al., Mixed matrix membranes containing MOF's for ethylene/ethane separation. Part A: Membrane preparation and characterization, Journal of Membrane Science, 428, 2013, 445-453.
- [3] J. Ploegmakers et al., Mixed matrix membranes containing MOF's for ethylene/ethane separation. Part B: Effect of Cu_3BTC_2 on membrane transport properties, Journal of Membrane Science, 428, 2013, 331-340.

PhD defenses

- December 13, 2013, 16.45 h, University of Twente
Jeroen Ploegmakers, Membranes for Ethylene/Ethane Separation
- January 31, 2014, 16.45 h, University of Twente
Enver Guler, Anion Exchange Membranes for Reverse Electrodialysis

Erik Roesink, new part-time professor

After his successful career at X-Flow, Erik Roesink has been appointed as a part time professor in the Membrane Science and Technology group at the University of Twente.

In the eighties, Erik Roesink, did his PhD at the same university in the Membrane Group, headed by Prof. Dr. C.A. Smolders. In these early days, he worked on the development of microporous capillary membranes based upon polymer blends, typically poly-ether-sulphone and poly-vinyl-pyrrolidone. Two patents were filed already during his PhD program. This work formed the basis for the start of X-Flow, and still forms the basis for their product line. He had several positions in X-Flow. After having been the managing director for 10 years, he spent the last years as Director of Innovation in developing new product lines. Most appealing here is the new platform for capillary nano-filtration products based upon modified poly-ether-sulphone, and now introduced by Pentair, the new owner of X-Flow. He left X-Flow officially per 1 April this year. Since October 2012, he is appointed part-time professor in the Membrane Science and Technology Group of the University of Twente, headed by Prof. Dr. Ir. Kitty Nijmeijer. Given his background it is more than obvious that he focuses his research on polymeric membranes. His research line addresses the development of novel membranes and the application of membrane technology for water treatment, e.g. water purification, desalination,

membrane bioreactors and waste water treatment. More specific, subjects for his research are:

- **Solvent free membranes** – Most polymeric membranes are based upon the phase inversion process, that starts with a polymer solution in aprotic solvents like, NMP, DMF, DMAc, all being heavily under pressure by new European Regulation coming up (REACH). Though in the past several routes are being explored, there is strong need for sustainable, solvent free membrane production processes.
- **Functionalization of membranes** – Membranes that demonstrate a specific function or better combine more than one function, e.g. filtration and adsorption are requested in aqueous applications. Examples are the functionalization of UF/NF/RO membranes towards the rejection (and degradation) of micro-pollutants, by applying e.g. a layer-by-layer approach.
- **Development of novel capillary NF and RO membranes** – Novel materials, combined with nanomaterials, applied in new membrane formation processes will be explored to find new production ways.



Erik Roesink

Prize at international conference ECCE 2013



Vic van Dijk

Vic van Dijk (28) won the 3rd prize with his poster presentation on the 9th European Congress of Chemical Engineering (ECCE9, The Hague). This international congress had about 1800 visitors, 750 of these presented their work with a poster. During the conference dinner, the jury announced that Vic has earned an iPad mini for his poster and enthusiastic story. For Vic's PhD research, he would like to functionalize the enormous internal surface of a polymeric filtration membrane. The membrane is therefore given a dual function, thereby being beneficial for the production and product quality of food products. All pore surface of the sponge-like membrane structure will be covered by silica nano spheres; the fluid flowing through the membrane will

only 'feel' silica. Certain compounds, from e.g. orange juice or beer, will bind to the silica spheres by adsorption.

"This is only the start, in the end one wants to do more exciting things with the big surface area of the inside of a membrane. A lot of surface in a small volume means that one can do a lot of chemistry, thus leading to a decrease in use of energy and raw materials. Therefore my research fits well in the conference theme 'Shaping a Sustainable Future,'" Vic says. This research will last for about three more years within the research groups Soft matter, Fluidics & Interfaces (SFI) and Membrane Science & Technology (MST) of the faculty Science and Technology and the institute MESA+ of the University of Twente. This research is also part of NanoNextNL, a micro and nanotechnology consortium of the Government of the Netherlands and 130 partners.

More information: Vic van Dijk, v.h.a.vandijk@utwente.nl; +31 (0) 6 5236 2229.



CapWa: Capturing of water vapor from industrial applications - End conference

As final event and closure of the European project entitled CapWa, the project partners organize a CapWa End Conference open for those interested in this technology and its future perspective. It is a great pleasure to invite you for this event, which will take place on Thursday August 29, 2013 in The Hague, The Netherlands. The conference will be hosted by DNV KEMA on behalf of the CapWa consortium.

At this conference, scientist from universities, representatives from the industry and scientific detachments of different embassy's in water stressed areas will come together to discuss the opportunities and challenges we face in transforming our water and energy future.

CapWa: CapWa is an international consortium consisting of thirteen international partners, among which the European Membrane Institute of the Membrane Science and Technology Group of the University of Twente and DNV Kema, which started in 2010 a EU funded project entitled CapWa or "Capturing of evaporated Water using novel membranes". This project aimed to realize the production of membranes and membrane modules for the selective removal and recovery of evaporated water from industrial applications, such as power plants (flue gas treatment), the pulp and paper industry or geothermal wells. Major focus was especially on the up scaling of the membrane and module production and real pilot plant testing on a larger scale. More information of CapWa can be found at: <http://www.dnvkema.com/innovations/energy-efficiency/capwa/default.aspx>



Results: The consortium has made important progress to supply the global population and industry with a "new source of water", that at the same time saves energy. Next to fundamental research in alternative water vapor selective membranes, significant steps forward in terms of membrane and module production has been achieved and pilot scale membrane modules are produced. Currently, pilot scale performance evaluation of these membranes is performed inside the flue gas duct of a gas and coal-fired power plant, inside a cooling tower of a geothermal well and in a paper mill.

Conference: During the end conference on August 29, 2013, we would like to share with you the final results of this project. In addition we have interesting speakers who will share with you their thoughts on the impact of this technology on the global water (and energy) shortage. The details of the program can be found at: <http://www.dnvkema.com/events/Invitation-CapWa-End-Conference.aspx>. You can seize this opportunity and learn all about this water capture technology by registering through the website <http://www.dnvkema.com/events/registration-capwa-end-conference.aspx>. We look forward to seeing you in the Hague on August 29!

Location: Hilton The Hague, Zeestraat 35, 2518 AA The Hague, The Netherlands

More information: For more information, please contact Dr. Zandrie Borneman (EMI Twente), z.borneman@utwente.nl, www.utwente.nl/tnw/emi



brabant Water



sappi



MEMBRANA

gasNatural fenosa

New member

Responsive polymer brushes as on-off switch for protein molecules

Name

Namık Akkılıç

Origin

Turkish

Contact

+31 (0) 53 489 2107

n.akkilic@utwente.nl



Namık Akkılıç studied at the Hasan Polatkan High School with extended science education, where after he started his studies in Physics at the Yildiz Technical University. Meanwhile, he completed an internship at the Ford Calibration Laboratories. His final BSc. project supervised by Prof. G. Dereli was on the “Electronic Properties of Single Wall Carbon Nanotubes”. After he obtained his BSc degree in 2003, he successfully completed the study for a MSc. degree in Bioengineering in 2006, at the same university, under the supervision of Prof. M. Mustafaev. His MSc thesis, titled “Investigation of Water-Soluble Complexes and Covalent Conjugates of Polyacrylic Acid with Bovine Serum Albumin by HPLC”, was published in the journal of Applied Polymer Science. From 2005-2008 he worked as a full time research assistant in the Bioengineering Department. In that period, he collaborated with Dr. V. Chegel (Institute of Semiconductor Physic, Ukraine) and experienced on Surface Plasmon Resonance Spectroscopy of polymer-protein complexes.

In January 2008, he joined the group of Prof T.J. Aartsma and Prof. G.W. Canters at the Leiden Institute of Physics, The Netherlands as a Marie Curie Early Stage Researcher in the EdRox Research and Training Network. The research was aimed at the control of single electron transfer events of a metalloprotein immobilized on a surface. The approach, so-called FluRedox principle, is based on Förster resonance energy transfer (FRET) in a suitably labeled redox protein, where a site-specifically attached, fluorescent dye-label (the donor) and the redox center (the acceptor, with a characteristic absorption spectrum) form a FRET pair. The FRET efficiency depends on the overlap integral of emission and absorption bands of the donor and acceptor, respectively. Thus, changes in the absorbance upon reduction or oxidation of the protein can be monitored via changes in the fluorescence intensity of the covalently attached label. Fluorescence detection provides a much enhanced sensitivity compared to absorbance measurements, down to the single-molecule level.

In his PhD work, it was shown that fluorescence-detected electrochemistry and chemical control of the redox state-changes of a metalloprotein provide excellent methods to explore the kinetic and thermodynamic mechanisms of redox proteins at the single-molecule level. Especially, fluorescence detected electrochemistry may be used for further investigation of protein-electrode or protein-protein interactions. The methods can be easily applied to many other redox proteins or enzymes, and have potential for applications in fluorescence-based biosensors and molecular electronics.

His work was presented at the Gordon Research conference (Italy) on Single Molecule Approaches to Biology, the European Biophysics Congress (Italy), the Workshop on Single Molecule Spectroscopy (Berlin) and several national conferences. Oral presentations were given at the Biosensor World Congress (UK), the Dutch Meeting on Protein Chemistry (Veldhoven) and in EdRox Network meetings in Modena, Oxford and Leiden.

Starting May 2013, he continues his academic career as a postdoctoral fellow at the Membrane Science and Technology Group at the University of Twente. He will be working under the coordination and supervision of Prof. Dr. Kitty Nijmeijer and Dr. Wiebe de Vos, in the project titled “Responsive Polymer Brushes as an on-off switch for Protein Molecules”. In his part of the work, he will graft mixed polymer brushes onto solid substrates and selectively immobilize biomolecules on responsive polymer brushes through a covalent attachment. There are several methods will be involved in the work, e.g., ellipsometry, atomic force microscopy (AFM), total internal reflection fluorescence (TIRF) microscopy. Hence, he will try to support the experimental results with theoretical simulations.

The Faculty of Science and Technology at the University of Twente represents a multidisciplinary environment for higher education and frontier research at the interfaces of applied physics, chemical technology and biomedical engineering. Key research topics include nanotechnology, sustainable energy, biomedical technology and technical medicine.

One of the important research themes of the faculty is Membrane Science & Technology. The group is the only academic polymer membrane group in The Netherlands and internationally leading in the field of membranes for Energy and Water Applications. Knowledge valorization occurs through the European Membrane Institute Twente (EMI Twente), which is a separate entity within the research group.

Within the research group Membrane Science and Technology of the University of Twente, we have a vacancy for a Ph.D. position.

1 Ph.D. position: “Salinity Gradient Energy: Hydrodynamics, fouling and scale up” (location: TTIW Wetsus, Leeuwarden, NL)

Reversed Electro Dialysis (RED or Salinity Gradient Energy) is a new, sustainable and very attractive technology for the production of energy from the mixing of fresh and salt water. In RED, a concentrated salt solution and a less concentrated salt solution are brought into contact through an alternating series of anion exchange membranes (AEM) and cation exchange membranes (CEM) to generate electricity. During the last years major steps have been made regarding the development of this technology.

To improve the process and to come to further development towards large-scale application, this project includes three directions: 1) the reduction and control of fouling, 2) improvement of hydrodynamics in the different compartments of the RED stack and 3) further scale up of the system by integrating all insights from current research. Of course improvements regarding fouling and hydrodynamics will directly be implemented at the system level as well.

The research will be conducted at Wetsus in Leeuwarden, NL (www.wetsus.nl) under the supervision of the Membrane Science and Technology group, faculty of Science and

Technology of the University of Twente (www.utwente.nl/tnw/mst).

1 Ph.D. position: “Salinity Gradient Energy: Membrane design and development” (location: University of Twente, Enschede, NL)

One of the key issues in the RED process are the ion exchange membranes. Currently available membranes, which are not specially developed for RED do not fulfill the requirements for application in RED and generate only low power outputs. In addition, fouling and fouling control are major aspects to a large extent governed by the chemistry of the membrane. Further improvement towards economically viable power production requires the development of ion exchange membranes especially designed for RED. With smart design of membrane chemistry, morphology and surface structure, we intend to control ion transport and fouling behavior in a RED stack leading to high power outputs and improved membrane life times.

The research will be conducted within the Membrane Science and Technology group of the faculty of Science and Technology of the University of Twente in Enschede, NL (www.utwente.nl/tnw/mst) in close collaboration with Wetsus in Leeuwarden, NL (www.wetsus.nl).

We are looking for highly motivated and enthusiastic researchers with an MSc degree in chemical engineering or a related topic, with adequate experimental and theoretical skills.

We prefer candidates with a good team spirit, who like to work in an internationally oriented environment. Fluency in English is a requirement. An interview and a scientific presentation will be part of the selection procedure.

We offer you a PhD position for 4 years. Your starting salary will be € 2083, - gross per month in the first year and up to € 2664, - gross per month in the last year.

Interested candidates are invited to send, by email, a motivation letter, curriculum vitae (including references) and a list of BSc and MSc courses and grades to Prof. Dr. Ir. Kitty Nijmeijer (d.c.nijmeijer@utwente.nl; phone: +31 53 489 4185).



Follow us on Twitter: The Membrane Science and Technology group has his own Twitter account!
Follow @MST_UTwente for the latest news of the MST group in a nutshell!

PhD defense Olga Kattan

Membranes in the biobased economy - Electrodialysis of amino acids for the production of biochemicals

On Friday March 22, 2013 at 16:30h, Olga Kattan defended her Ph.D. thesis entitled “Membranes in the biobased economy: Electrodialysis of amino acids for the production of biochemicals”. The defense took place in the building Waaier of the University of Twente.



Within the scope of this Ph.D. thesis, electrodialysis (ED), an electro-membrane process that uses an electrical potential difference over the membrane as driving force for the selective extraction of ions from solutions, was applied for the separation of amino acids. Amino acids can be obtained from biomass feedstocks and are interesting as chemical intermediates, as amino acids already have the functionalities (i. e. $-N$ and $-O$) required for the production of chemicals. However, based on the differences in their charge behavior with respect to pH, only fractionation into three main groups (basic, acidic and neutral) can be obtained in practice.

A novel approach that combines enzymatic modification, for instance by using an amino acid specific decarboxylase

which removes the acidic group of the corresponding amino acid changing its charge behavior, is applied to basic, acidic and neutral amino acids. In this way intermediate building blocks for chemicals are produced and isolation of single amino acids can be achieved. The approach was validated for the separation of complex biobased mixtures. Finally, mixed matrix membranes as support for enzyme immobilization were prepared and successfully integrated in the electrodialysis stack achieving enzymatic conversion and separation in one single unit operation. A preliminary cost evaluation indicated the directions to further optimize the process, and should focus on increasing amino acid flux through the membrane and decreasing the cost of the membranes to make this approach cost effective. Altogether this work provides a contribution to promote the shift of conventional refinery toward a biobased economy.



For more information please contact Prof. Dr. Kitty Nijmeijer (d.c.nijmeijer@utwente.nl; phone: + 31 (0)53 489 4185).

EMS travel grant for Jeroen Ploegmakers and Salman Shahid

Jeroen Ploegmakers and Salman Shahid both received an EMS Travel Award of €500 for the North American Membrane Society (NAMS) conference from 8 – 12 June in Boise, Idaho. The awards have been given to young professionals based on quality and originality of their work and educational background. The NAMS is the only professional society in North America that promotes all aspects of membrane science and technology. Their conference is the largest

yearly membrane conference hosted in the United States of America. Conference sessions range from fundamental studies of membrane material science and membrane fabrication to process applications for e.g. water treatment, inorganic membranes and membranes for gas separation. The aim of the conference is to bring together academic professionals and industrial vendors from the field of membrane technology to stimulate contacts and to exchange

new ideas related to their work.

Jeroen Ploegmakers is a PhD student at the Membrane Science & Technology Group (MST) of University of Twente.



Jeroen's work is dedicated to fabricate Mixed Matrix Membranes (MMMs) for ethylene/ethane separation. This particular Jeroen received the grant for his work on the effect of three different Metal Organic Frameworks (MOFs) in

the polyimide P84® on the ethylene permeability and the ethylene/ethane selectivity. Addition of 20 w% Cu₃BTC₂ increases the selectivity with 71% compared to the native polymer membranes. In addition, a thorough analysis of the ethylene transport mechanism through MMMs will be presented during the NAMS.

Salman Shahid is a PhD scholar in the framework of the Erasmus Mundus Doctorate in Membrane Engineering

(EUDIME) at the Membrane Science and technology group of the University of Twente with a tri-sandwich PhD programme with KU Leuven-Belgium and UM2-France.



Salman's work deals with polymer-Metal Organic Frameworks (MOFs) architectures for gas separation. This particular project describes the performance of mixed matrix membranes containing the Fe(BTC) MOF in Matrimid-PI for carbon dioxide (CO₂) and

methane (CH₄) separation at high pressures. At high pressures Matrimid membranes shows typical gas separation behavior but for MMMs transport properties seem to be controlled by the MOF particles. At a pressure of 40 bar, 30% MMM shows a selectivity increase of 108% compared to pristine Matrimid membranes.

For more information please contact Prof. dr. ir. Kitty Nijmeijer (d.c.nijmeijer@utwente.nl; phone: + 31 (0)53 489 4185).

Publications

- O.M. Kattan Rendi, H.J. Kuenen, H.J. Zwijnenberg, K. Nijmeijer, Novel membrane concept for internal pH control in electrodialysis of amino acids using a segmented bipolar membrane (sBPM), *Journal of Membrane Science* 443 (2013) 219-226.
- Wojciech Ogieglo, Herbert Wormeester, Matthias Wessling, Nieck E. Benes, Temperature-induced transition of the diffusion mechanism of n-hexane in ultra-thin polystyrene films, resolved by in-situ spectroscopic ellipsometry, *Polymer* 54-1 (2013) 341-348, doi: 10.1016/j.polymer.2012.11.038
- O.M. Kattan Rendi, M. Girones, K. Nijmeijer, Separation of complex mixtures of amino acids for biorefinery applications using electrodialysis, *Journal of Membrane Science* 429 (2013) 338-348, doi: 10.1016/j.memsci.2012.11.053
- A. Alhadidi, B. Blankert, A.J.B. Kemperman, R. Schurer, J.C. Schippers, M. Wessling, W.G.J. van der Meer, Limitations, improvements and alternatives of the silt density index, *Desalination and Water Treatment*, 51/4-6 (2013) 1104-1113, doi: 10.1018/19443994.2012.705049
- Jeroen Ploegmakers, Susilo Japip, Kitty Nijmeijer, Mixed matrix membranes containing MOF's for ethylene/ethane separation. Part A: Membrane preparation and characterization, *Journal of Membrane Science* 428 (2013) 445-453, doi: 10.1016/j.memsci.2012.11.014
- Jeroen Ploegmakers, Susilo Japip, Kitty Nijmeijer, Mixed matrix membranes containing MOF's for ethylene/ethane separation. Part B: Effect of CU₃BTC₂ on membrane transport properties, *Journal of Membrane Science* 428 (2013) 331-340, doi: 10.1016/j.memsci.2012.11.013
- E. Karabudak, R. Kas, W. Ogieglo, D. Rafieian Boroujeni, S. Schlautmann, R.G.H. Lammertink, J.G.E. Gardeneris, G. Mul, Disposable attenuated total reflection-infrared crystals from silicon water: A versatile approach to surface infrared spectroscopy, *Analytical chemistry* 85 (2013) 33-38, doi: 10.1021/ac302299g
- D. Vermaas, S. Bajracharya, B. Bastos Sales, M. Saakes, B. Hamelers, K. Nijmeijer, Clean energy generation using capacitive electrodes in reverse electrodialysis, *Energy & Environmental Science* 6-2 (2013) 643-651, doi: 10.1039/c2ee23562e
- D. Vermaas, M. Saakes, K. Nijmeijer, Fouling in reverse electrodialysis under natural conditions, *Water Research* 47-3 (2013) 1289-1298, doi: 10.1016/j.watres.2012.11.053
- S.M. Dutczak, F.P. Cuperus, M. Wessling, D. Stamatialis, New crosslinking method of polyamide-imide membranes for potential application in harsh aprotic solvents, *Separation and purification technology* 102 (2013) 142-146, doi: 10.1016/j.seppur.2012.10.018
- Membrane Technology 13: On the progress in membrane research in The Netherlands and Belgium, K. Bijkerk (editor), A. Kemperman (secretary - NMG), S. van de Wouwer (secretary - BMG), Posterday 7th June 2012, ISBN 978-90-365-3490-1

Membrane Science and Technology

Vision

The research group Membrane Science and Technology of the University of Twente, headed by Prof. Kitty Nijmeijer, focuses on the multidisciplinary topic of polymer membranes to control mass transfer through interfaces.

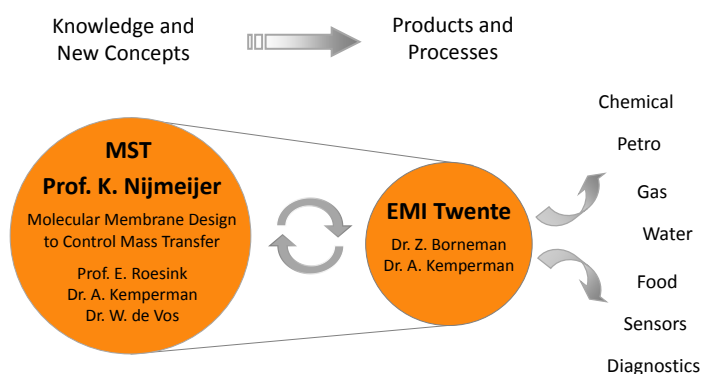

Figure 1 - Organizational structure research group.

The group consists of two separate entities (Figure 1): the academic research group Membrane Science and Technology (MST) and the European Membrane Institute Twente (EMI), which performs confidential research directly with the industry.

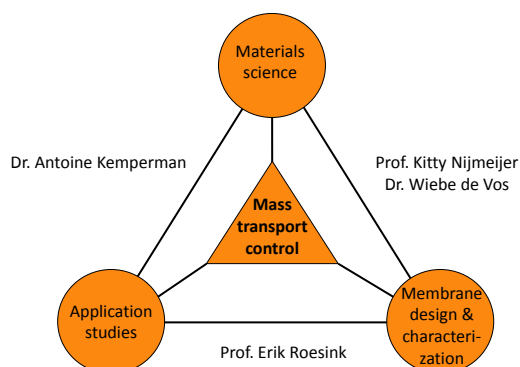

Figure 2 - Membrane Science & Technology.

Research within the group is dedicated to the design, development, characterization and application of polymer membranes for Energy, Water and Life Sciences. We aim at tailoring membrane design, morphology and characteristics on a molecular level to control mass transport in applications (Figure 2). More specifically, our research focuses on the separation of molecular mixtures and achieving selective mass transport. We consider our expertise as a multidisciplinary knowledge chain ranging from molecular design towards process applications.

Most of our research is dedicated towards specific applications. We distinguish three main application clusters, i.e. Energy, Water and Life Sciences (Figure 3).

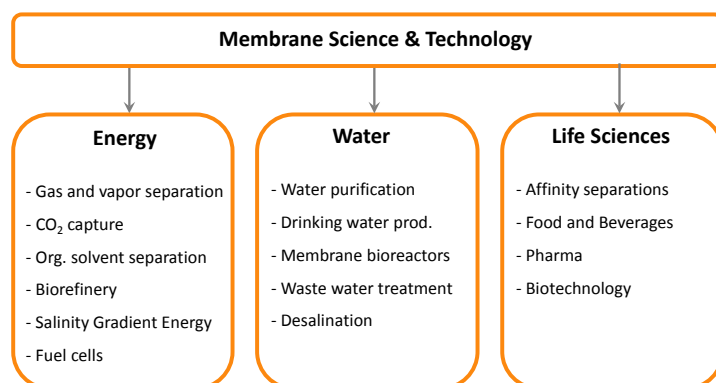

Figure 3 - Major application clusters Membrane Science & Technology.

Energy

The research cluster Energy is dedicated to the molecular design and synthesis of polymer membranes for e.g. gas and vapor separations (CO₂ capture, olefin/paraffin separation,



water vapor removal), biorefinery applications, fuel cells and the generation of energy from the mixing of salt and fresh water ('salinity gradient energy' or Blue

Energy). Relevant research aspects are control of structure-properties relationships, ultimate selectivity, molecular recognition, and separation of complex, multi-component mixtures.

Water

Within the application cluster Water, research addresses the development of membranes and the application of membrane technology for water treatment, e.g. water purification, desalination, membrane bioreactors and waste water treatment. In particular it investigates the relation between membrane design, morphology and membrane properties in relation to performance, selectivity and causes, consequences and control of fouling.

Life sciences

The cluster Life Sciences focuses on the design of porous membranes to separate complex multicomponent mixtures in pharmaceutical, food, beverage and biotech applications. Important subjects are the tuning of the material properties and structure (e.g. pore morphology and porosity), the

development of functional materials (e.g. affinity separations of biomolecules) and the creation of new and/or improved processes (e.g. faster processes, higher yields, less fouling). In addition, aspects related to process design and industrial implementation, such as scale-up of novel membrane fabrication methods, are investigated. The research group consists of 30-35 people among which approximately 15-20 Ph.D. students, three permanent researchers, five B.Sc. and M.Sc. students and five academic staff members. Next to the head of the group, Prof. Kitty Nijmeijer, the staff consists of Prof. Erik Roesink, Dr. Wiebe de Vos, Dr. Antoine Kemperman and Dr. Zandrie Borneman, who is responsible for the EMI Twente. Next to extensive, general knowledge on polymer membrane science and technology, each of the staff members has his/her own specific field of dedicated expertise (Table 1).

Table 1 - Specific expertise of the staff members of MST.

Name	Specific expertise
Prof. Kitty Nijmeijer	Membrane design and characterization, molecular selectivity, molecular recognition, dense membranes, Energy and Water
Prof. Erik Roesink	Membrane formation, porous systems, phase inversion, solvent-free membranes, biomimetic membranes, Water and Life Sciences
Dr. Antoine Kemperman	Causes, consequences, cleaning and control of membrane fouling, interactions at the interface, Water European Membrane Institute (EMI) Twente: Confidential contract research directly with the industry
Dr. Wiebe de Vos	Membrane surface science, surface modification, multilayers, polymer brushes, Water and Energy.
Dr. Zandrie Borneman	European Membrane Institute (EMI) Twente: Confidential contract research directly with the industry

Knowledge valorization

Our group has decided to establish a significant effort in the valorization of its knowledge. The European Membrane Institute Twente (EMI Twente) was established in 1995 and performs confidential contract research directly with the

industry and public organizations. Research is governed by questions from stakeholders. To guarantee confidentially, we work with highly skilled researchers with longstanding experience in membrane technology

in our group. Students are not involved. EMI Twente creates, transfers and translates (fundamental) scientific knowledge into products, processes and applications. Projects can last from only a few days up to three years and can involve membrane development and synthesis, membrane characterization, and/or membrane application studies. The EMI Twente acts as the interface between the academic research and the industrial needs.

Services

The EMI Twente provides the following services:

- Membrane development
- Membrane characterization
- Membrane application studies
- Desktop studies
- Consultancy
- Selling of equipment (e.g. test cells for gas separation, UF and MF, casting knives, cloud point meters, hollow fiber spinning lines and spinnerets)



More information

For more information, please contact:

Prof. Dr. Kitty Nijmeijer

d.c.nijmeijer@utwente.nl

www.utwente.nl/tnw/mtg

Dr. Zandrie Borneman (EMI Twente)

z.borneman@utwente.nl

www.utwente.nl/tnw/emi

MNT- Information

Membrane News Twente is published two times per year and aims to inform the membrane community about the activities of the Membrane Technology Group of the University of Twente (membrane@utwente.nl www.utwente.nl/tnw/mtg).

Editors

Kitty Nijmeijer

Enver Güler