

UNIVERSITY OF TWENTE.

Windesheim 

# Emission modelling on Junctions in Urban Networks

Development and assessment of a static macroscopic junction emission model for CO<sub>2</sub>, NO<sub>x</sub> and PM<sub>10</sub>



R.H. (Ruud) Gasthuis

Master Thesis

January 23th, 2015

## Colophon

Title: Emission modelling on Junctions in Urban Networks

Subtitle: Development and assessment of a static junction emission model for CO<sub>2</sub>, NO<sub>x</sub> and PM<sub>10</sub>.

Date: January 23<sup>th</sup>, 2015

Author: R.H. (Ruud) Gasthuis  
Student number: s0138851  
Email: [r.h.gasthuis@gmail.com](mailto:r.h.gasthuis@gmail.com)  
Telephone number: 06 1865 8548

Institution: Windesheim  
Lectureship: Area Development  
Daily supervisor: Drs. Ing. E.M. (Erwin) Bezembinder

Institution: University of Twente  
Faculty: Engineering Technology (CTW)  
Research group: Centre for Transport Studies  
Master: Civil Engineering and Management  
Track: Traffic Engineering and Management  
UT – supervisor: Prof. Dr. Ir. E.C. (Eric) van Berkum  
Supervisor: Dr. Ir. L.J.J. (Luc) Wismans

## Summary

### Background and objectives

In the planning phase of a project, traffic network designers have a lot of choices to make when designing junctions in urban networks. The traffic network designers base the design choices, among others, on design guidelines for junctions. These design guidelines contain a set of rules based on rules of thumb and decision diagrams. The main criteria for these rules and decision diagrams are traffic flow and safety. A check is usually performed for costs and local criteria while guidelines for emissions, noise and fuel consumption barely exist (Bezembinder, 2013; CROW, 2012). However, the environment is becoming a more important subject nowadays. And policies are more and more based on minimizing the five most important (negative) external effects of traffic: congestion, traffic safety, global warming, air pollution and noise pollution.

Research of Bezembinder is aimed to develop new junction design rules for urban traffic networks in the Netherlands, reckoning with those policy objectives. The research described in this document aims to contribute to the research of Bezembinder by developing an emission modelling approach which can determine emissions values of isolated junctions. In the research of Bezembinder a junction model is used that produces macroscopic static flow data. An emission model that is able to use these data should be connected to the junction model to calculate emission values of different junction designs. With the results the junction designs should be compared to each other. Furthermore, the approach should not be calculation capacity and calculation time consuming because it has to be used in a network situation. Therefore, the objective of this research is:

*The objective of this research is to develop a static macroscopic junction emission model which produces results that can be used to compare different junction designs on policy relevant emission substances.*

### Method

In order to achieve the objective first a literature research is executed. This literature research showed that carbon dioxide (CO<sub>2</sub>), nitrogen oxides (NO<sub>x</sub>) and particulate matter (PM<sub>10</sub>) are the policy relevant substances that should be modelled. After that, it is found that external effects of traffic are modelled with effect models. These models use traffic performances to calculate the external effects of traffic. Emission models are also effects models and used for modelling emissions of traffic. The exhaust of the emissions is the variable that is determined by traffic emission models. The emissions caused by traffic are usually calculated by the product of an emission factor and the number of vehicle kilometres, the equation is:

$$\text{emission of substance} = E \times l \times q$$

With:

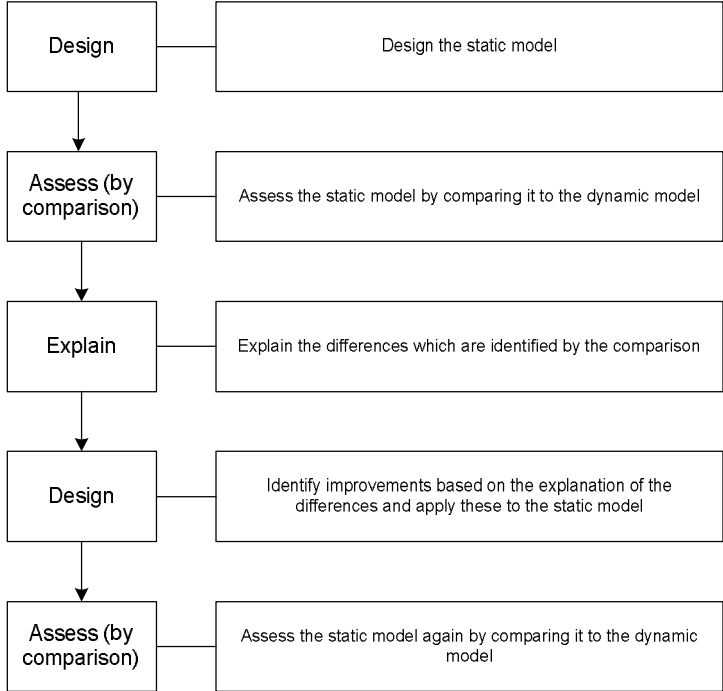
*E = emission factor of substance (grams per vehicle kilometre)*

*l = length of the road section (kilometres)*

*q = load on the road section (vehicles per hour)*

It is concluded that a traffic situation based emission model is most promising for macroscopic use. However, no existing traffic situation emission model uses macroscopic static traffic flow data. The traffic situation based model of Wismans (2012) combines a dynamic traffic assignment (DTA) model with the traffic situation based emission model ARTEMIS. This model is chosen as the base for the static macroscopic junction emission model because ARTEMIS is a traffic situation based emission model. It is already based on macroscopic traffic data but still includes variations in traffic speed. Last argument is that the DTA model (OmniTRANS) is able to include the effects of junctions into the performances of the network by a junction module. In the approach of Wismans (2012) a traffic state is determined (free flow, heavy, saturated and stop & go) and the associated emission factor is used for calculating the emission value. This model is used for calculating emissions on links based on dynamic macroscopic traffic data. It should be changed for calculating emission on junctions instead of links. Furthermore, it should be based on static macroscopic traffic data instead of dynamic macroscopic traffic data.

After the literature research an iterative design process is executed. This process is shown in Figure 1.



**Figure 1: Overview of the research strategy**

The first step in the design process is to design a first static macroscopic junction emission model. This model is based on the queue length per turn which, on its turn, is determined by the average delay per vehicle per turn complemented with reasoning for combined approach lanes and the blocking effect. For this model only the stop & go traffic state is used. This model is assessed by comparing it to the dynamic macroscopic junction emission model which uses all four traffic states. This model is an adaptation of the dynamic model for emission modelling on links of Wismans (2012). The adaptation is made by including junction effects in the emission modelling method. The static and dynamic model are applied to the modelling framework to generate a set of emission values. This modelling framework contains eighteen junction designs and four traffic demand patterns which are applied to total junction demands between 500 and 3500 vehicles per hour. The emission values of the combinations of junction design and junction demand are also calculated for three speed

limits. This results in 864 combinations of junction designs and input criteria sets (combining junction demands and speed limits). The emission values are used in the assessment framework to assess the static model. The assessment framework contains the comparison of three elements:

1. Best option with 5% bandwidth. Determining the junction design with the lowest emission value with a 5% bandwidth per input criteria set. The junction design with the lowest emission value and the junction designs that score maximal 5% higher are listed as best option. For each input criteria set is determined if one of the listed junction designs for the static model is also listed for the dynamic model. If this is the case for minimal 95% of the input criteria set then the static model meets the requirements.
2. A total rank of all junction designs per input criteria set. These are compared with a Wilcoxon signed rank test.
3. The absolute emission values. These are compared with a Wilcoxon signed rank test too.

The differences between the static model and dynamic model are explained in order to identify improvements to the static model. The explanation showed that the static model overestimates the stop & go length and that the heavy and saturated traffic states have a significant impact on the emission values for the dynamic model while these are not included in the static model. Furthermore, the dynamic model determines differences in traffic performance per speed limit while the static model does not. Based on this explanation it is tried to improve the static model. The calculation of the stop & go length is improved by setting a maximum queue length per turning direction and by changing the reasoning for the combined approach lanes and blocking effect. The second improvement is made by including the heavy and saturated traffic states into the emission modelling method. Finally, the improved static model is assessed again by comparing it to the dynamic model using the same assessment framework as at the first assessment.

### **Static macroscopic junction emission model**

The result of the process is the final static macroscopic junction emission model. This model determines the values for CO<sub>2</sub>, NO<sub>x</sub> and PM<sub>10</sub>. The static macroscopic junction emission model determines emission values for these substances in four steps:

1. Determine the queue length per turning direction
2. Determine the stop & go length per turning direction
3. Determine the emissions per turning direction and total junction
4. Add up the emissions caused by heavy and saturated traffic state

The queue length calculation is based on the average delay per vehicle per turn. The maximum queue length per turn is the load on that turn multiplied with the vehicle length. The queue length is determined by the equation:

$$Q_t = d_t \times q_t \times l_{veh}$$

With:

$Q_t$  = queue length per turn  $t$  (kilometres)

$d_t$  = average delay per vehicle on turn  $t$  (hours)

$q_t$  = load on turn  $t$  (vehicles per hour)

$l_{veh}$  = vehicle length (kilometres)

The stop & go length is introduced to determine the length of the link where vehicles pass the junction in a stop & go traffic state. The stop & go length is determined by including reasoning for different approach lane configurations and including the blocking effect. The stop & go length is used for the emission calculation. For the stop & go length, vehicles pass the approaching link in the stop & go traffic state. The emission values of the junctions based on the stop & go lengths per turn are calculated with:

$$junction\ emission_{sg} = \sum_t SG_t \times E_s(sg) \times q_t$$

With:

$SG_t$  = length for which the stop & go traffic state is determined for turn  $t$  (kilometres)

$E_s(sg)$  = stop & go emission factor for speed limit  $s$  (grams per vehicle kilometre)

$q_t$  = load on turn  $t$  (vehicles per hour)

In the last step, the emissions caused by the heavy and saturated traffic states are added to the stop & go junction emission. For the calculation of these emissions the heavy and saturated percentages are needed. These percentages are dependent on the weighted load capacity ratio and the maximum of the loads on one of the approaching links. In the calculation the heavy and saturated percentages are translated into the length on the approach lane on which the heavy and saturated traffic states occur and factors to calculate the emissions are added. The equation for this calculation is:

$$junction\ emission_{hs,s} = p_{hs,s} \times 2 \times q_{tj} \times E_s(hs)$$

With:

$p_{hs,s}$  =

percentage of heavy or saturated traffic state  $hs$  present at junction per speed limit  $s$

$q_{tj}$  = load on total junction  $tj$  (vehicles per hour)

$E_s(hs)$  = emission factor for heavy or saturated traffic state  $hs$  for speed limit  $s$  (grams per vehicle kilometre)

Finally these emission values are added to the junction emission of the stop & go traffic state to form the total junction emission, the equation is:

$$junction\ emission = \sum_{ts} junction\ emission_{ts}$$

With:

junction emission = total junction emission (grams)

junction emission<sub>ts</sub> = junction emission per heavy, saturated

or stop & go traffic state  $ts$  (grams)

Final assessment shows that the static model only produces satisfying results for the best option determination for CO<sub>2</sub>. For NO<sub>x</sub> and PM<sub>10</sub> the static model does not meet the requirements for this assessment. At NO<sub>x</sub> the sub set 70 km/h produces a 100% score and the percentage of the total set is a little higher. The percentages for PM<sub>10</sub> are exactly equal for all (sub) sets. The Wilcoxon signed rank tests show more random differences for all three substances. Similarity for all three substances is that less sub sets are assessed as equal. Furthermore, for absolute emission values the static model do not meet the requirements for all three substances.

### **Implications and future research**

This research led to a static macroscopic junction emission model. With this model junction designs can be compared for the emissions of CO<sub>2</sub>, NO<sub>x</sub> and PM<sub>10</sub>. As already stated the model does not meet the requirements for the use on absolute emission values and determination of the best option for NO<sub>x</sub> and PM<sub>10</sub>. The modelling framework represented a small part of all possible junction designs, junction demands and speed limits. In relation to the research of Bezembinder in which this research is conducted for, the model can be improved and extended. Especially, because the junction emission model is intended to use for network calculation instead of individual junction design calculation. Therefore, it is tried to develop a model which can be extended to network level.

Analysis of the traffic performances showed that the dynamic model does determine different traffic performances per speed limit. However, the traffic performances of the static model are equal for all three speed limits. Therefore, the emission calculation can be improved by including the effects of different speed limits. Because the parameters for the determination of the heavy and saturated traffic states are already estimated per speed limit, these effects only have to be included for the stop & go length.

Another suggestion is to determine the heavy and saturated traffic states per approaching link instead of the total junction. This means that the weighted load capacity ratio cannot be used because this is a measure for the total junction. Therefore, the load capacity per approaching link is determinative for the heavy and saturated impact on the total emission value of that link.

With the current insights about static macroscopic emission modelling on junctions in relation with the research of Bezembinder it is suggested that first all wished elements influencing junction traffic performances (e.g. more junction design variables or including other vehicle types) are included in the junction modelling. This is necessary because parameters have to be estimated for calculating the emission values. Each additional element influences the parameter values.

# Contents

List of figures .....	8
List of tables .....	9
Table with symbols .....	10
1 Introduction.....	11
1.1 Motive.....	11
1.2 Research objective .....	12
1.3 Research scope.....	12
1.4 Reading guide.....	14
2 Theoretical framework.....	15
2.1 Emission substances .....	15
2.2 Emission modelling.....	17
3 Research methodology.....	23
3.1 Research strategy .....	23
3.2 Modelling framework .....	24
3.3 Assessment framework .....	26
3.4 Configuration of the dynamic junction emission model.....	27
4 Design: static macroscopic emission model .....	29
4.1 Stop & go length.....	29
4.2 Static model parameters.....	35
5 Assess: Assessment I .....	36
5.1 Best option with 5% bandwidth .....	36
5.2 Wilcoxon signed rank test.....	37
5.3 Conclusion.....	39
6 Explain: Explanation of differences in assessment I .....	40
6.1 Differences between substances .....	40
6.2 Differences in speed limits.....	43
6.3 Absolute differences.....	45
6.4 All best options.....	47
6.5 Conclusion.....	47
7 Design: Improvements for the static model .....	48
7.1 Stop & go percentage .....	48
7.2 Heavy, saturated and stop & go traffic states.....	50
8 Assess: Assessment II .....	54



8.1	Wilcoxon signed rank tests .....	56
8.2	Conclusion.....	57
9	Conclusions.....	58
9.1	Conclusion.....	58
9.2	Implications and future research directions .....	62
10	Literature .....	64
Appendices.....		66
A	Appendix: OmniTRANS delay calculation .....	66
A.1	Delay calculation for an equal junction .....	66
A.2	Delay calculation for a priority junction .....	68
A.3	Delay calculation for a signalized junction.....	72
A.4	Delay calculation for an un-signalized roundabout.....	77
B	Appendix: Junction designs .....	83
B.1	Equal junctions .....	83
B.2	Priority junctions .....	83
B.3	Signalized junctions .....	84
B.4	Roundabouts .....	87
C	Appendix: Calculation procedure of exit rates .....	88
C.1	Total traffic demand calculation example .....	89
D	Appendix: Calculation average speed on dynamic junction.....	90
E	Appendix: Scatter plots for heavy and saturated percentages .....	91
E.1	Scatter plots for heavy percentages 30 km/h.....	91
E.2	Scatter plots for heavy percentages 50 km/h.....	92
E.3	Scatter plots for heavy percentages 70 km/h.....	93
E.4	Scatter plots for saturated percentages 30 km/h .....	94
E.5	Scatter plots for saturated percentages 50 km/h .....	95
E.6	Scatter plots for saturated percentages 70 km/h .....	96

## List of figures

Figure 1: Overview of the research strategy .....	2
Figure 2: Elements on a junctions.....	13
Figure 3: General emission modelling framework.....	17
Figure 4: Connection between average speed on a link and the emission factor.....	20
Figure 5: Delay calculation methods for static and dynamic modelling .....	21
Figure 6: Overview of the research strategy .....	23
Figure 7: main direction of traffic stream on the start of a collector road .....	25
Figure 8: Symbols for approach lane arrangements.....	31
Figure 9: Turn numbers.....	31
Figure 10: Stop & go length on approaching link for two situations.....	40
Figure 11: Indexed emission factors (indexed to free flow emission factor).....	42
Figure 12: Average delay and average speed per speed limit.....	44
Figure 13: Average speed - speed limit ratio per speed limit .....	45
Figure 14: Average CO <sub>2</sub> value per vehicle.. ..	46
Figure 15: Average NO <sub>x</sub> value per vehicle.....	46
Figure 16: Average PM <sub>10</sub> value per vehicle.. ..	47
Figure 17: From queue lengths per turn to a stop & go length.....	49
Figure 18: Options for including heavy and saturated traffic state into the static model.....	50
Figure 19: Fundamental diagram.....	52
Figure 20: definition of radius in roundabouts (Bezembinder & Brandt, 2013) .....	79
Figure 21: relation between $\alpha_b$ and $d_{c,c'}$ .....	80
Figure 22: 101 equal junction.....	83
Figure 23: 102 equal junction with mid-verge on main direction .....	83
Figure 24: 201 priority junction main direction straight ahead .....	84
Figure 25: 202 priority junction with mid-verge main direction straight ahead .....	84
Figure 26: 203 priority junction main direction turn .....	84
Figure 27: 204 priority junction with mid-verge main direction turn.....	84
Figure 28: 301 signalized junction equal traffic streams single approach lane.....	85
Figure 29: 302 signalized junction equal traffic streams double approach lanes .....	85
Figure 30: 303 signalized junction equal traffic streams triple approach lanes.....	85
Figure 31: 304 signalized junction main stream straight ahead.....	85
Figure 32: 305 signalized junction main stream turn .....	85
Figure 33: 306 signalized junction main stream one direction .....	85
Figure 34: 307 signalized junction all equal traffic streams double exit lanes.....	86
Figure 35: 308 signalized junction main stream straight ahead double exit lanes .....	86
Figure 36: 309 signalized junction main stream turn double exit lanes .....	86
Figure 37: 310 signalized junction main stream one direction double exit lanes .....	86
Figure 38: 401 single lane roundabout .....	87
Figure 39: 402 double lane roundabout .....	87
Figure 40: Standard junction scheme .....	88

## List of tables

Table 1: Overview of components in the modelling framework.....	26
Table 2: Best option with 5% bandwidth assessment for CO <sub>2</sub> .....	36
Table 3: Best option with 5% bandwidth assessment for NO <sub>x</sub> .....	37
Table 4: Best option with 5% bandwidth assessment for PM <sub>10</sub> . ....	37
Table 5: Wilcoxon signed rank test for CO <sub>2</sub> .....	38
Table 6: Wilcoxon signed rank test for NO <sub>x</sub> .....	38
Table 7: Wilcoxon signed rank test for PM <sub>10</sub> . ....	39
Table 8: Percentages equal and not equal at best option with 5% bandwidth at 30 km/h.....	41
Table 9: Weighted traffic states percentages for junction demand criteria 2500 vehicles per hour ....	41
Table 10: Ranks for junction demand criteria 2500 vehicles per hour and turn demand pattern.....	41
Table 11: Stop & go percentages before and after queue length improvements.....	49
Table 12: Heavy and saturated percentages.....	51
Table 13: Parameters for heavy and saturated percentage determination .....	53
Table 14: Best option with 5% bandwidth assessment for CO <sub>2</sub> .....	54
Table 15: Best option with 5% bandwidth assessment for NO <sub>x</sub> .....	55
Table 16: Best option with 5% bandwidth assessment for PM <sub>10</sub> . ....	55
Table 17: Wilcoxon signed rank test for CO <sub>2</sub> .....	56
Table 18: Wilcoxon signed rank test for NO <sub>x</sub> .....	56
Table 19: Wilcoxon signed rank test for PM <sub>10</sub> . ....	57
Table 20: Parameters for heavy and saturated percentage determination .....	59
Table 21: Best option with 5% bandwidth assessment for CO <sub>2</sub> , NO <sub>x</sub> and PM <sub>10</sub> .....	61
Table 22: Total traffic coupled to junction direction .....	88
Table 23: Initial O/D-matrix for main stream straight ahead.....	88
Table 24: O/D-matrix for main stream straight ahead .....	89
Table 25: O/D-matrix main stream all equal .....	89
Table 26: O/D-matrix main stream turn .....	89
Table 27: O/D-matrix main stream one direction .....	89
Table 28: O/D-matrix for the main direction straight ahead in vehicles per hour .....	89

**Table with symbols**

<b>Symbol</b>	<b>Variabele</b>
<i>Q</i>	Queue length (kilometres)
<i>t</i>	Turn
<i>E</i>	Emission factor (grams per vehicle kilometre)
<i>s</i>	Speed limit (km/h)
<i>q</i>	Load (vehicles per hour)
<i>a</i>	Link segment
<i>v</i>	Average speed (km/h)
<i>l</i>	Length (km)
<i>L</i>	Left
<i>S</i>	Straight ahead
<i>R</i>	Right
<i>A</i>	All directions
<i>W</i>	Left and straight ahead direction
<i>P</i>	Right and straight ahead direction
<i>SG</i>	Stop & go length (kilometers)
<i>d</i>	Link type
<i>m</i>	Vehicle class
<i>j</i>	Jam
<i>k</i>	Density (vehicles per kilometre)
<i>c</i>	Capacity
<i>hs</i>	Heavy or saturated traffic state
<i>tj</i>	Total junction
<i>ts</i>	Heavy, saturated or stop & go traffic state

# 1 Introduction

This chapter forms the introduction of the research. First the motive is provided in section 1.1. This leads to the research objective and main research question in section 1.2. Section 1.3 provides the scope of the research. Finally, in section 1.4 the reading guide for the research report is provided.

## 1.1 Motive

In the planning phase of a project, traffic network designers have a lot of choices to make when designing junctions in urban networks. The first choice is the main junction type, for example: an equal junction, a priority junction, a signalized junction or a roundabout. After that, the junction has to be designed further. Choices about approach lanes, exit lanes, signalization schemes, arrangements for cyclists and pedestrians and other design variables have to be made.

The traffic network designers base the design choices, among others, on design guidelines for junctions. These design guidelines contain a set of rules based on rules of thumb and decision diagrams. The main criteria for these rules and decision diagrams are traffic flow and safety. A check is usually performed for costs and local criteria while guidelines for emissions, noise and fuel consumption barely exist (Bezembinder, 2013; CROW, 2012). However, the environment is becoming a more important subject nowadays. And policies are more and more based on minimizing the five most important (negative) external effects of traffic: congestion, traffic safety, global warming, air pollution and noise pollution.

Research of Bezembinder is aimed to develop new junction design rules for urban traffic networks in the Netherlands, reckoning with those policy objectives. This research is executed by using a modelling approach which means that all necessary data is generated using models. To achieve the goal, first junction design rules for isolated junctions are determined. After that these rules are analysed on and adjusted to network level. Finally, the rules are included in a decision support tool for junctions in urban networks. This decision support tool can aid traffic network designers with multi-objective junction design choices in urban traffic networks including the policy objectives.

The research described in this document aims to contribute to the first part of the research of Bezembinder. In the research of Bezembinder a junction model is used that produces macroscopic static flow data. An emission model that is able to use these data should be connected to the junction model to calculate emission values of different junction designs. An emission modelling approach which can determine emissions values of isolated junctions is developed. This emission modelling approach should be incorporated into the research of Bezembinder resulting in three criteria.

The first requirement is that the emission modelling approach should produce emission values of substances produced by traffic and relevant for policy makers because the intention of the decision support tool is to incorporate relevant policy objectives. Second requirement is that the modelling approach should produce results that can be used to compare the junction designs to each other because the decision support tool is intended to provide information which is useful for traffic network designers. This means that the differences in emission performances between junction designs should be determined in a way that traffic network designers can decide what the best option is. Additionally, the modelling approach should use little calculation capacity and calculation time because in a latter stage it will be used to determine emission values of junctions in traffic

networks instead of isolated junctions. Furthermore, the junction designs in the network have to be optimized for the five policy objectives, which on itself is already a calculation and time expensive operation.

Existing emission models for junctions are dynamic microscopic or dynamic mesoscopic emission models. Advantage of these models is that changes in speed, which often occur on junctions, are included in the traffic performances. However, the disadvantage is that these models are calculation capacity and calculation time consuming. Furthermore, the accuracy of these models is questioned because of the high number of parameters included in the model (Hourdakis, Michalopoulos, & Kottommannil, 2003; Wismans, 2012). In comparison to microscopic or mesoscopic models, the static macroscopic emission models use less calculation time and calculation capacity. Though, it is difficult to incorporate speed changes within these models.

## **1.2 Research objective**

For emission modelling on junctions static macroscopic emission models do not exist. Despite the fact that it is difficult to include speed changes still a static macroscopic emission model is needed because the calculation capacity and calculation time are important criteria. Therefore, a static macroscopic junction emission model should be developed. This model has to produce results that can be used to compare different junction designs on policy relevant emission substances.

*The objective of this research is to develop a static macroscopic junction emission model which produces results that can be used to compare different junction designs on policy relevant emission substances.*

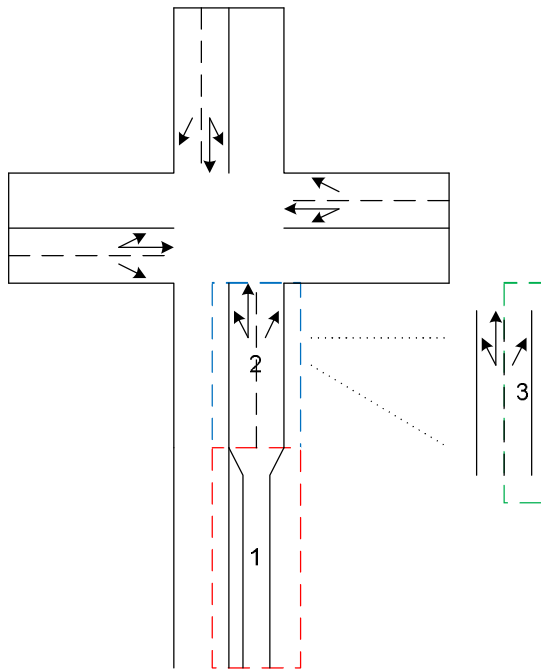
The goal can be achieved when the following main research question is answered:

*In what way can emission exhaust of traffic on junctions in urban networks be modelled using static macroscopic emission modelling to compare different junction designs on policy relevant emission substances?*

To answer the main research question the three criteria are further specified in chapter two. Based on this chapter and the motive the research methodology is derived in chapter three. This methodology leads to an answer on the main question.

## **1.3 Research scope**

First the difference between approaching link, approach lanes and approach lane configuration is provided because it can be confusing when the exact meaning of these concepts are not clear. Figure 2 provides an overview of these concepts. The approaching link is the link leading towards the junction which is number 1 in the figure. The approach lane configuration is the total of the lanes that serve all turn directions, number 2 in the figure. The approach lane is the lane that serves one or more turn directions which is number 3 in the figure.



**Figure 2: Elements on a junctions**

As mentioned in the motive a junction can be designed on many design variables. Furthermore, this design is dependent on junction demand criteria and network criteria. Together this makes many variation possibilities which must be taken into account. Not all these possibilities are included in this research because of the available time. The junction design variables, the junction demand criteria and the network criteria are further specified in this section to give direction and focus to the research.

In this research an emission model is developed for four arm junctions. The reasoning can be used on junctions with less or more arms but the calculation methods are different. For the four arm junctions a variation of junction designs is used for testing the junction emission model. The wide range of junction designs present in urban networks is tried to cover. Junction design variable that is not included in the research is the signalling scheme for signalized junctions. The variation in signalling schemes can be large and this is a complicated procedure by itself. Therefore, this can be a research on its own and is not included within this research. The junction designs are specified in the modelling framework (section 3.2).

The junction demand criteria are explained as the type of vehicles passing the junction and the number of vehicles passing the junctions. For this research only cars are included in the modelling framework. Despite, heavy traffic is called an important cause of emissions on junctions this vehicle type is not included in this research. The reason for this is that it is believed that the reasoning of the cars can also be applied to other vehicle types. For that types only some different parameter values have to be used. Another junction demand requirement not included is slow traffic consisting of cyclists and pedestrians. These do have effect on the traffic performances. Though, it is assumed that effects of slow traffic are included in the calculation of the traffic performances when it is required. Furthermore, public transport is not incorporate either. The number of vehicles passing the junction is called the demand of the junction. As can be imagined, this demand can have many variations and therefore it is tried to cover a range of those possibilities by using four demand patterns

differentiated by main direction. These demand patterns are: all equal, straight ahead, turn and one direction and further specified in the modelling framework, section 3.2.

The network criteria are the last elements. As mentioned in the motive, this research is about junctions in urban networks. This is a specification of the network type in which the junctions should be included. Furthermore, the choice to investigate three speed limits which often occur in urban networks: 30, 50 and 70 kilometres per hour.

An additional subject in this research scope is the second requirement mentioned in the motive: the modelling approach should produce results that can be used to compare the junction designs to each other. This is a requirement for the junction emission model but it is difficult to use for the design of the junction emission model because it is a requirement for the output of the junction emission model. Therefore, this requirement can only be used for assessing the results of the model. To still include this requirement in the development process it is chosen to use an iterative process for the design of the junction emission model. This means that based on the assessment and analysis of the assessment improvements are made to the junction emission model. After implementing these improvements the junction emission model is assessed again. Herewith all three criteria are included in the development of the junction emission model. Another consequence of this requirement is that the accelerating traffic is not taken into account. The assumption is that independently of the junction design the acceleration pattern is about the same. Since the model should be designed to compare different junction designs to each other, including the acceleration part into the emission calculation does not improve this comparison.

#### **1.4 Reading guide**

This report contains nine chapters from which the first was this introduction. Chapter two provides the theoretical framework in which the criteria identified in the motive are further specified. In chapter three the research methodology is provided. Among others, the research strategy is provided. This strategy is an iterative process of: design – assess – explain – design – assess. The chapters after the methodology all contain one element of this process. In chapter four, a first static macroscopic junction emission model is designed. This model is assessed in chapter five. The assessment is explained in chapter six. Based on this explanation, improvements to the model are identified in chapter seven. Finally, the model is assessed again in chapter eight. The report finishes with conclusions, discussion points, implications of the research and directions for future research in chapter nine.



## **2 Theoretical framework**

In this theoretical framework the two criteria for the development of the junction emission model are further specified. As mentioned in the scope, the third requirement is included in the assessment of the framework. The first requirement is that the model determines emission values for policy relevant substances. In the first section of this chapter three substances are identified which are policy relevant. The second requirement is that the model should use little calculation capacity and calculation time. This requirement is already specified in the research objective and the research scope by the statement that a static macroscopic junction emission model should be developed based on an existing junction emission model type. To achieve this, the second section of this chapter provides existing emission models and identifies a model type on which the static macroscopic junction emission model is based.

### **2.1 Emission substances**

Emissions can have an influence on the climate on the one hand and the air quality on the other hand. Based on relevant policy documents and emission standards the substances are identified that should be modelled with the junction emission model starting with the emissions influencing the climate.

#### **2.1.1 Emissions influencing climate**

Greenhouse gasses are present in the atmosphere. These gasses absorb the infrared radiation that is reflected by the surface of the earth and therefore retain heat in the atmosphere. Normally, it is regulated by many processes called the carbon cycle. Human activities causing a big release of greenhouse gasses are disturbing this carbon cycle and this leads to global warming (Augustijn, 2006; Wismans, 2012). Different components in the atmosphere act like greenhouse gasses, these are carbon dioxide (CO<sub>2</sub>), water vapour (H<sub>2</sub>O) and methane (CH<sub>4</sub>) (MilieuCentraal). CO<sub>2</sub> is the most prominent greenhouse gas in the atmosphere and human activities influence mainly the emission of this gas. Therefore the total amount of greenhouse gasses is expressed in CO<sub>2</sub>-equivalents. Approximately 20% of the greenhouse gasses is caused by traffic and transport (Wismans, 2012). Road traffic CO<sub>2</sub>-emissions are caused by engines using gasoline or diesel and are directly proportional with the fuel consumption. 93% of the engines of road traffic use gasoline or diesel (CBS & PBL, 2013).

Policy on different levels (global, European and national) is made to lower the emission of greenhouse gasses. On global level the Kyoto Protocol is in force. This agreement has the goal to annually lower the greenhouse gasses for industrialized countries with 5.2% in the period of 2008-2012 compared with 1990. For the Netherlands it means an annually reduction of greenhouse gas emissions of 6%. The former EU-15 countries agreed to lower the emission of greenhouse gasses with 8%. To meet this goal, the Netherlands uses the possibility of emission trading. They buy emission rights from other countries to meet the goal of the EU-15 countries. To overcome future problems caused by climate change the European Council has set a new goal for the emission of greenhouse gasses. They agreed to lower the greenhouse gas emissions by 20% in the year 2020 compared to 1990 (CBS, PBL, & UR, 2011).

#### **2.1.2 Emissions influencing air quality**

The air quality is influenced by a number of emissions. Emissions that have an undesirable effect are called air pollution. These emissions can be divided into two groups: natural emissions and

anthropogenic emissions. Examples of natural emissions are animals, volcanic eruptions and forest fires. Anthropogenic emissions are emissions caused by human activity, like: traffic, generating electricity, industrial activities, agriculture, etc. Anthropogenic emissions are usually divided into two categories: stationary sources (e.g. factories) and mobile sources (e.g. traffic). The effects of this air pollution could be divided into direct and indirect effects. Health damage caused by direct contact with air pollutants is categorized as direct effects. Air pollution that have negative influences on the environment and consequently harming our health and wellbeing are categorized as indirect effects (e.g. acid rain) (Augustijn, 2006). Human activities cause direct or indirect effects by disturbing the balance of different substances in the air including: nitrogen dioxide ( $\text{NO}_2$ ), particulate matter ( $\text{PM}_{10}$ ), sulfur dioxide ( $\text{SO}_2$ ), nitrogen oxides ( $\text{NO}_x$ ), benzene ( $\text{C}_6\text{H}_6$ ), carbon monoxide ( $\text{CO}$ ), ozone ( $\text{O}_3$ ), arsenic (As), cadmium (Cd), lead (Pb), nickel (Ni) and benzo(a)pyrene (B(a)P) (CBS, PBL, & UR, 2013b). The most important substances that are produced by traffic are  $\text{NO}_x$ ,  $\text{NO}_2$ ,  $\text{PM}_{10}$ ,  $\text{CO}$ ,  $\text{SO}_2$ , and hydrocarbons (e.g.  $\text{C}_6\text{H}_6$ ) (Wismans, 2012).

Air quality regulations are made on European level because air pollution can spread over a wide area and does not stop on nation borders. For every country emission ceilings are agreed and captured in the National Emission Ceilings (NEC) guidelines. Different substances need to be measured and the concentrations should not be higher than the thresholds. Furthermore, air quality standards are determined and source based regulation is made for specific target groups like: industry, agriculture, traffic and consumers. On national level, policy is made to meet the NEC guidelines. Air quality standards are set for  $\text{SO}_2$ ,  $\text{NO}_x$ ,  $\text{NH}_3$  and volatile organic components. According to the emission registration problems occur with the air quality standards concerning  $\text{NO}_x$  and  $\text{PM}_{10}$  (CBS, PBL, & UR, 2013a). The annually concentration standards for these two substances are:  $30 \mu\text{g}/\text{m}^3$  for  $\text{NO}_x$  and  $40 \mu\text{g}/\text{m}^3$  for  $\text{PM}_{10}$  (CBS, PBL, & UR, 2013c).

Nitrogen oxides ( $\text{NO}_x$ ) are part of the acidifying substances. It is formed by all combustion processes with air and the main source of  $\text{NO}_x$  is road traffic (about 60% (CROW, 2010)). First the nitrogen ( $\text{N}_2$ ) reacts with oxygen ( $\text{O}_2$ ) to nitric oxide (NO). After that the NO reacts with oxygen in the air and forms nitrogen dioxide ( $\text{NO}_2$ ). This substance can react with water ( $\text{H}_2\text{O}$ ) to nitric acid ( $\text{HNO}_3$ ) which is the most important component of acid rain (Augustijn, 2006). Particulate matter ( $\text{PM}_{10}$ ), or aerosols, are particles smaller than 10 micrometer. This is formed by natural processes (e.g. dust and forest fires) and by human activities (Wismans, 2012). Traffic generates  $\text{PM}_{10}$  by the combustion of diesel, about 80% of total traffic production, and 20% of the total traffic production by wearing from road surface, tires and braking (CBS, PBL, & UR, 2010). Locally, traffic can be responsible for 20% of the total  $\text{PM}_{10}$ -concentration. Human can inhale these particles and this can harm the health. Furthermore, other substances like organic pollution or heavy metals could be attached to the particles which cause health damage too (Augustijn, 2006).  $\text{PM}_{10}$  also affects the thermal management of the earth and the generation of precipitation and smog (Wismans, 2012).

### 2.1.3 Conclusion

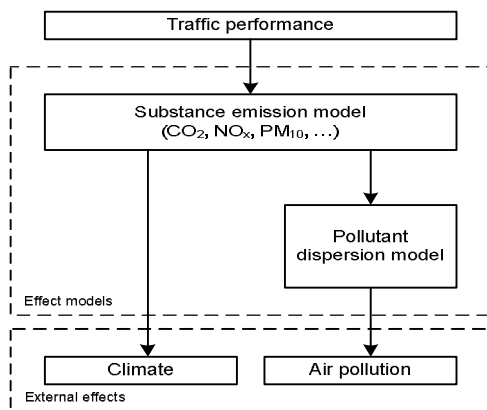
Further specification of the first requirement led to three substances that are modelled with the junction emission model. For the effect on the climate this is carbon dioxide ( $\text{CO}_2$ ) because this is the most important substance. For the effect on air quality these are nitrogen oxides ( $\text{NO}_x$ ) and particulate matter ( $\text{PM}_{10}$ ) because problems occur with the standards for these substances.

## 2.2 Emission modelling

In this section the existing emission model type is identified on which the static macroscopic junction emission model is based. This model is identified based on an overview of the existing emission modelling methods. To get a better understanding of emission modelling, first, the general emission calculation method is elaborated. After that, an overview of emission modelling approaches on different scale levels is provided. Subsequently, an overview of emission models is provided. Based on these overviews an emission model type is identified on which the static macroscopic junction emission model is based.

### 2.2.1 General emission calculation method

In general, external effects of traffic are modelled with effect models. These effect models use traffic performances to calculate the external effects of traffic. Figure 3 shows the framework of this principle. This is a adaptation of a more general framework of Wismans (2012) in which also other external effects like safety and noise are incorporated.



**Figure 3: General emission modelling framework**

The real point of interest in emission modelling is the number of people affected by the emission. This can be determined by modelling the concentrations of emissions. The effect models for emission execute this usually in two steps. The first step is to calculate the amount of emissions caused by traffic. The second step is to calculate the dispersion of these emissions to the environment (Wismans, 2012). The dispersion of the emission is dependent on the wind speed, wind direction, weather conditions, type of road surface and location of screens and buildings. The dispersion is not included in this research because junction designs, as investigated in this research, have no influence on the dispersion. Type of road surface and location of screens can be designed but these are not factors that will be investigated. Furthermore, the other factors influencing dispersion (wind speed, wind direction, weather condition) cannot be influenced by the junction design at all.

The exhaust of the emissions is the variable that is determined by traffic emission models. The emissions caused by traffic are usually calculated by the product of an emission factor and the number of vehicle kilometres, the equation is:

$$\text{emission of substance} = E \times l \times q$$

With:

$E$  = emission factor of substance (grams per vehicle kilometre)

$l$  = length of the road section (kilometres)

$q$  = load on the road section (vehicles per hour)

### **2.2.2 Scale levels in emission modelling**

Foregoing section showed that emission modelling is performed by combining a traffic model with an emission model. This section provides an overview of the scale levels on which the emission exhaust for traffic networks can be determined. These scale levels are different regarding calculation capacity and time and accuracy of the results.

First step in emission modelling is the generation of traffic performance measures. This is usually performed with a traffic model. In this traffic model the traffic can be loaded to the network in two ways: static loading and dynamic loading. Static loading models describe the interaction between travel demand and infrastructure supply, assuming that demand and supply are time-independent and therefore constant during the time period. And dynamic loading models are flow propagation models over time that calculate the resulting traffic conditions, taking changes in supply and demand over time into account (Wismans, 2012). In terms of calculation capacity and time, dynamic loading models need a lot more because in each time step the supply and demand are calculated again, while the static loading models calculate the supply and demand in one time.

Furthermore, the traffic performances (or junction performances) can be aggregated on different levels: microscopic level, macroscopic level and mesoscopic level. The emission models based on microscopic, macroscopic and mesoscopic traffic data will be called respectively microscopic emission models, macroscopic emission models and mesoscopic emission models. Microscopic emission models estimate instantaneous vehicle fuel consumption and emission rates that are then aggregated to estimate network-wide measures. Second-by-second vehicle characteristics and road conditions are required in order to estimate fuel consumption and emission rates in these models. Microscopic emission models capture transient changes in a vehicle's speed and acceleration level and capture the impact of intelligent transport system strategies such as traffic signal coordination. These models are, however, very expensive and labour intensive and they need very detailed information which may not be available (Fang & Elefteriadou, 2008; Faris, Rakha, Kafafy, Idres, & Elmoselhy, 2011; Marsden, Bell, & Reynolds, 2001; Yue, 2008). Macroscopic emission models use average aggregate network parameters or link-based parameters to estimate network-wide or link-based energy consumption and emission rates. Macroscopic emissions models ignore transient changes in a vehicle's speed and acceleration level and ignore the impact of intelligent transport systems. They are, however, less expensive and labour intensive than microscopic emission models and they need less detailed information which is more available. Furthermore, macroscopic emission modelling has been found highly relevant to road traffic and most helpful in estimating aggregate emissions inventories (Faris et al., 2011; Rakha, Aerde, & Trani, 2000; Yue, 2008). The input variables to mesoscopic emission models are more disaggregate than macroscopic emission models and more aggregate than microscopic emission models. Generally, mesoscopic emission models use a few explanatory variables (e.g. stopped delay, number of stops, driving mode, etc.) to estimate vehicle fuel consumption and emissions. Mesoscopic emission models can be used for computing average fuel consumption and emission rates for a specific facility type. Furthermore mesoscopic emission modelling has proved to strike a balance between simplicity and accuracy (Faris et al., 2011; Yue, 2008).

For the base of the static macroscopic junction emission model microscopic models are unsuitable for two reasons. The first reason is the concern about the accuracy of these models as mentioned in chapter one of this report. Second reason is that microscopic emission modelling has numerous parameters and assumptions that are very difficult to translate to a macroscopic model. Therefore, a more aggregated model type is used to base the static macroscopic junction emission model on.

### **2.2.3 Emission model types**

The emission factor used in the emission calculation equation, as mentioned in section 2.2.1, is determined by emission models. This emission factor is dependent on characteristics on traffic level (or road section level) and characteristics on vehicle level. Traffic volume, road design, composition of the car park and flow circulation are factors on traffic level. Among others, vehicle characteristics and car driver behaviour are factors on vehicle level. Most emission models deal with these traffic characteristics in a more or less detailed way (Hickman, 1999; Pandian, Gokhale, & Ghoshal, 2009; Smit, 2006; Wismans, 2012).

Wismans (2012) identified two basic types of emission models. These categories are differentiated by the collection method of the emission factors. The first one is based on bag measurements. Within bag measurements the total exhaust emissions are collected in a sample bag and analyzed after completion of the driving cycle. The second type of emission models is based on instantaneous measurements. Within this type of models the exhaust emissions are measured continuously. As mentioned in the foregoing section an aggregated modelling approach should be used to base the static macroscopic junction emission model on. Therefore, an emission model in the category bag measurements can be used because it has the same scale level. A continuous emission model includes too detailed emission information to connect with the macroscopic traffic data.

Within the bag measurements category three emission models are identified. Aggregated emission models, traffic situation based models and driving mode models. Aggregated emission functions use single emission factors representing a particular vehicle type and a general driving type. Traffic situation based models use aggregated traffic data that is referenced to traffic situations. Emission factors are correlated to these traffic situations. At driving mode models, emission factors are related to the driving state of the vehicle like: idle, deceleration, acceleration and cruising (Wismans, 2012).

Emissions near junctions are largely dependent on fleet speed, deceleration speed, queuing time, acceleration speed, queue length, and traffic flow rate (Pandian et al., 2009). The emission model to base the static macroscopic junction emission model on should include these parameters in some way in the emission factor. Therefore, aggregated emission models are not suitable because these models use only one general emission factor. The other two model types do include these variations more by using different emission factors for different traffic states or driving modes.

Wismans (2012) concluded that the focus in emission modelling lies in the development of traffic situation models for macroscopic applications. Traffic situation based models are used because high-emission events have been shown to have a large impact so these special, most short during, events are included in the emission calculation (Hickman, 1999; Wismans, 2012). This is also important for junctions because the short during changes in speed often occur. Therefore, the traffic situation based emission modelling approach is used as a starting model type for the development of the static macroscopic junction emission model. In the next section, this model type is further specified.

### 2.2.4 Traffic situation based emission model

The traffic situation based model developed by Wismans (2012) combines the traffic model OmniTRANS with the traffic situation based emission model ARTEMIS. Based on dynamic macroscopic traffic data the emissions are determined for links. This model is chosen as the base for the static macroscopic junction emission model because ARTEMIS is a traffic situation based emission model. Furthermore, it is already based on macroscopic traffic data but still includes variations in traffic speed. Last argument is that OmniTRANS is able to include the effects of junctions into the performances of the network by a junction module.

OmniTRANS is a transport planning application designed for integrated modelling of multi-modal transport systems. ARTEMIS is an emission database which includes emission factors for different traffic states (free flow, heavy, saturated and stop & go), a number of emission substances (e.g. carbon dioxide, nitrogen oxides) network characteristic (e.g. road type, speed limit) and vehicle characteristics (e.g. light or heavy vehicles). The average link speed is used to determine the emission factor on the link. The connection between the average speed and the emission factor is shown in Figure 4.

The principle of this figure is explained for the heavy traffic state. This traffic state occurs on a link or link segment when the average speed of that link or link segment has a value between the borders of this traffic state. The left border  $v_c$  is the speed  $v$  at capacity  $c$ . If, for example, the speed limit is 50 km/h and the speed at capacity is on 80% of this speed limit, the left border has value of 40 km/h. In that case the right border has value of  $(v_f + v_c)/2$  (where  $v_f$  is the free flow speed):

$$v_c + \frac{v_f - v_c}{2} = 40 + \frac{50 - 40}{2} = 45 \text{ km/h}$$

This is 90% of the speed limit. So the heavy traffic state occurs when the average speed lies between 80% and 90% of the speed limit. Which means in this case between 40 km/h and 45 km/h.

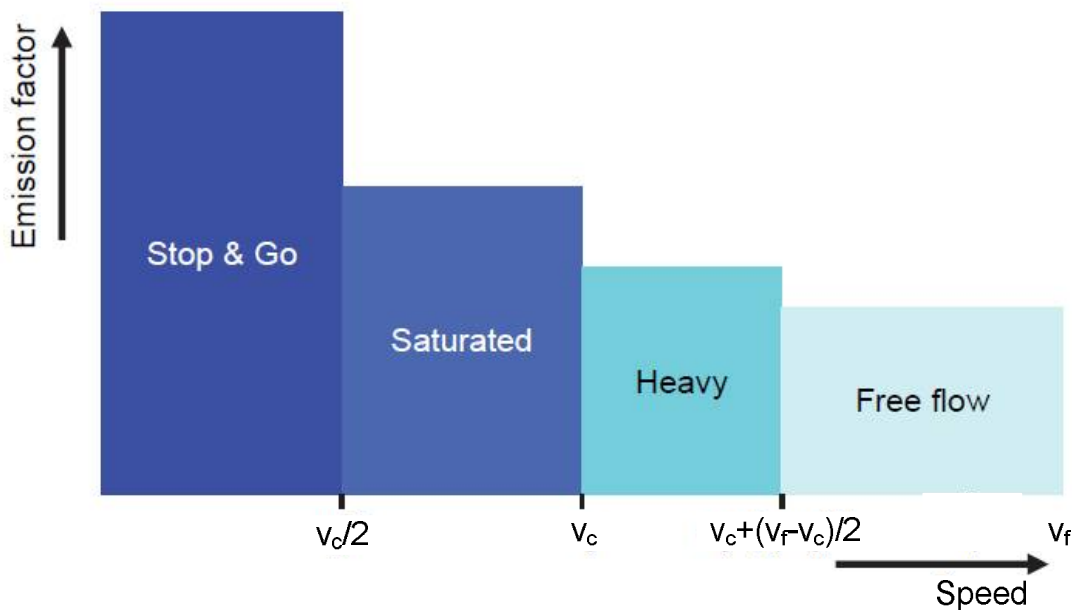


Figure 4: Connection between average speed on a link and the emission factor

As mentioned in the research scope only cars and urban link types are included in this research. Therefore, the emission results are calculated by:

$$emission\ of\ substance = \sum_t \sum_a q_{ta} \times E(v_{ta}) \times l_a$$

With:

$q_{ta}$  = load on time interval  $t$  on link segment  $a$  (vehicles per hour)

$E(v_{ta})$  = emission factor dependent on average speed  $v$  (grams per vehicle kilometre)

$v_{ta}$  = average speed on time interval  $t$  on link segment  $a$  (kilometres per hour)

$l_a$  = length of link segment  $a$  (kilometres)

### 2.2.5 Junction effects

As mentioned in the introduction of this section, OmniTRANS can include the effects of a junction to the network. These effects are included by determining the delay per turn. This delay is made up of three delay components: uniform delay, geometric delay and the incremental delay. The methods to calculate this delay are different for dynamic modelling and static modelling. This is illustrated in Figure 5. In this figure is shown that the three delay components together form the delay for static modelling. However, for dynamic modelling the uniform and geometric delay are determined by the dynamic model itself. Only the incremental delay is determined by the junction module. In Appendix A the calculation methods for the three delay components is provided. For the dynamic modelling the uniform and geometric delay are set to 0 in the static junction module. These delays are determined by the additional module XStream.

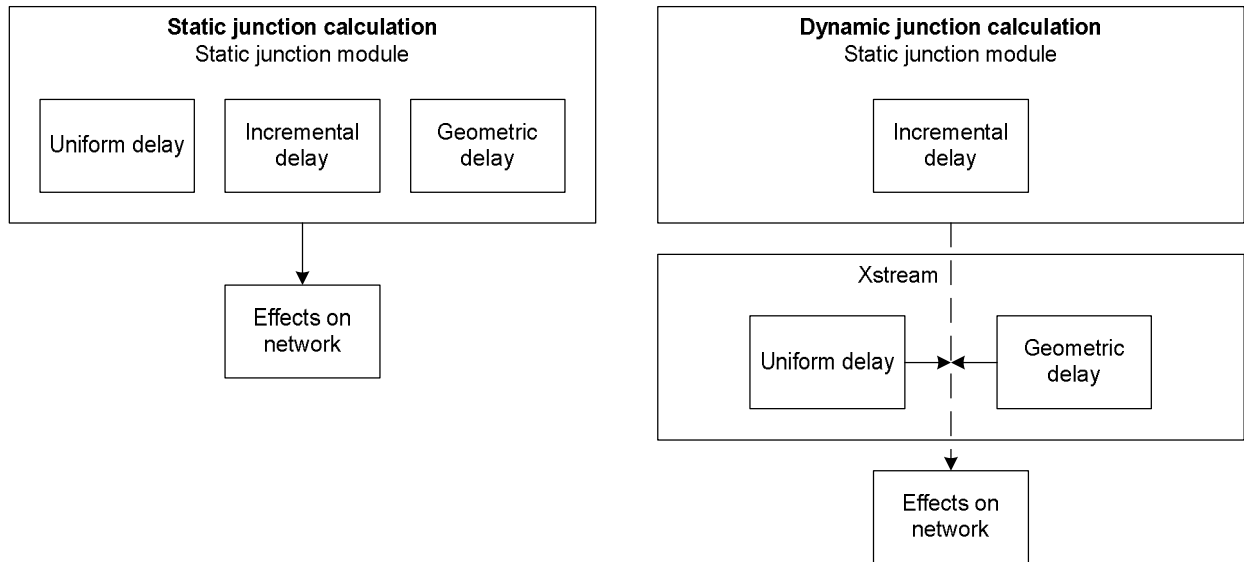


Figure 5: Delay calculation methods for static and dynamic modelling

### 2.2.6 Conclusion

This section started with the goal to identify an existing junction emission model type as a base for the static macroscopic junction emission model. First, different scale levels are described from which

the conclusion was derived that the base modelling approach should be an aggregated approach. After that, different emission models are described that are used within an aggregated modelling approach. It was concluded that a traffic situation based emission model is suitable for this research. Finally, the emission modelling approach of Wismans (2012) was chosen as a base model. However this modelling approach originally was used for determining emission on links, it is able to determine the effects of junctions on these links by adding the junction module and XStream to the model.



### 3 Research methodology

This chapter describes the research methodology. Section 3.1 describes the research strategy used for this research. Section 3.2 provides the modelling framework to which the developed model is applied. Section 3.3 provides the assessment framework which is used to assess the static macroscopic junction emission model. And section 3.4 provides the configuration of the dynamic junction emission model. Because of the readability of the document the static macroscopic junction emission model is called the “static model” and the dynamic macroscopic junction emission model is called the “dynamic model”.

#### 3.1 Research strategy

As mentioned in the research scope (section 1.3) the research is executed in an iterative way to include all three criteria. In Figure 6 an overview of this process is shown.

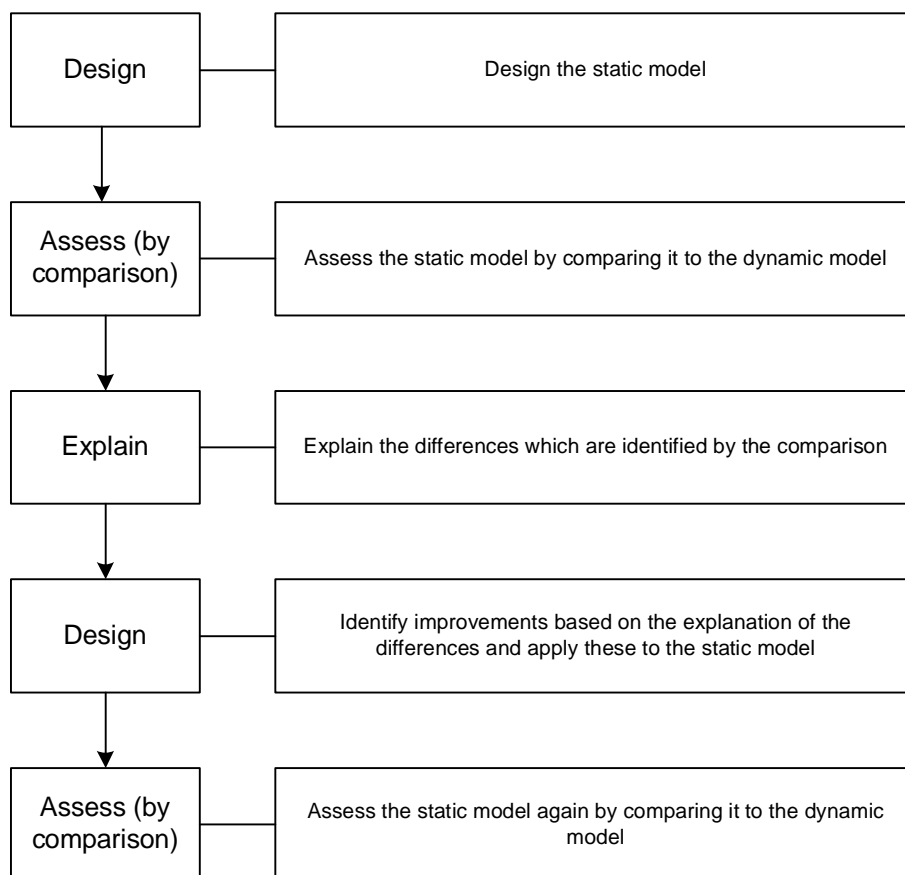


Figure 6: Overview of the research strategy

The process starts with the design of the static model. It is difficult to incorporate speed changes in a static macroscopic modelling approach. These are relevant because these often occur on junctions and are an important factor of emissions. Therefore, it is chosen to base the static macroscopic junction emission model on an existing emission model type which includes speed changes into the calculation of the emission values. In other words, it is tried to translate the assumptions and reasoning of an existing emission model type to a static macroscopic junction emission model. The base model is a traffic situation based emission model. This model is simplified to form the static model. The static model is a simplified model because in the second design step is based on a more detailed analysis taking the second requirement mentioned in the motive (section 1.1) into account.

Second step is to assess the static model. The dynamic model proved to be a good emission model and therefore, the assessment is performed by comparing the static model with the dynamic model. This method is also chosen because both models are based on the traffic model (OmniTRANS) and the included junction models have the same base for both situations. Assumptions forming the base for these models do, therefore, not influence the comparison results. To compare these models emission data is needed. This emission data is obtained by applying the models to the modelling framework (the modelling framework is described section 3.2). The assessment is performed to investigate whether the static model produces results that can be used to compare the junction designs to each other in order to provide useful information for the decision support tool. The comparison is executed by applying the emission results to the assessment framework (the assessment framework is described in section 3.3).

The differences identified in the assessment step are explained in the third step in order to identify possible improvements for the static model. The analysis of the differences is performed by scrutinising the reasoning used for the static model. Furthermore, the traffic performances are analysed by visual analysis, correlation tests and regression. Based on this analysis improvements are identified.

The last step is to assess the improved static macroscopic junction emission model again by comparing it again with the dynamic macroscopic junction emission model. For this step the assessment framework (section 3.3) is used again.

## **3.2 Modelling framework**

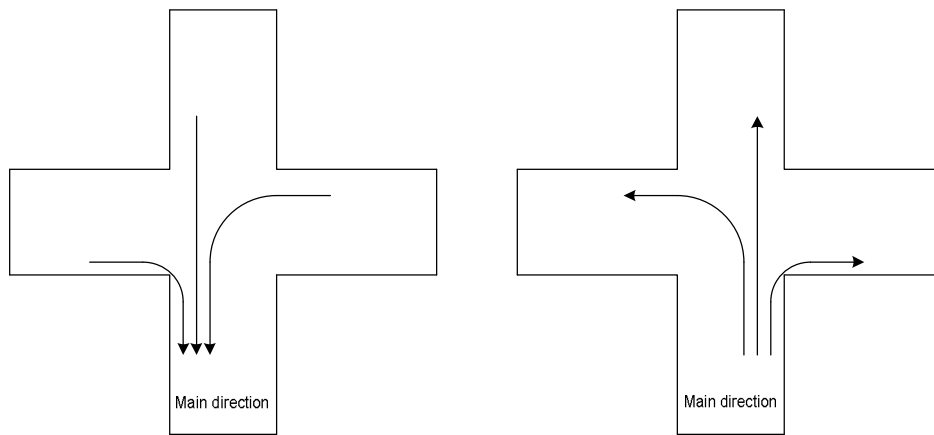
In order to obtain emission results for the analysis, both junction emission models are applied to the modelling framework elaborated in this section. As mentioned in the research scope (section 1.3) a junction design is dependent on junction demand criteria and network criteria. This means that the junction performance is dependent on: junction design variables, junction demand criteria and network criteria. Elaboration of these three factors leads to the modelling framework.

### **3.2.1 Junction design variables**

The junction design variables together form the junction design. As mentioned in the scope, four main junction types are used in the modelling framework to model a four arm junctions: equal junctions, priority junctions, signalized junctions and roundabouts. These main junction types are further varied by: presence of a mid-verge, approach lane configuration, priority scheme (for priority junctions), lanes on a roundabout. The used approach lane length is 100 metres for both models because this is a default configuration of the dynamic model.

Based on the main traffic streams on the junction, the junction design is chosen. For example, if the main traffic stream is straight ahead the junction design has more capacity for the main road than the other two connecting links on the junction. Four types of main directions are used on which the junction designs are chosen:

- All equal on which there is no main stream on the junction
- Straight ahead on which the main stream is straight ahead
- Turning direction on which the main stream is a turn to the left or to the right
- One main stream which could occur on a junction which is the start of a collector road from a residential area. This principle is shown in Figure 7.



**Figure 7: main direction of traffic stream on the start of a collector road**

A total of eighteen junction designs is used for the modelling framework. These are shown in Appendix B.

### **3.2.2 Junction demand criteria**

The junction demand criteria form the traffic that passes the junction. As mentioned in the scope of the research only cars are regarded. The junction demand criteria in this modelling framework are a combination of four traffic demand patterns and four total demands which results in sixteen demand sets that are loaded to the junctions. The modelling period will be one hour so unit used in the demand sets is vehicles per hour.

The demand patterns are connected to the four main directions on which the junction designs are based: all equal, straight ahead, turn and one direction. The results are origin destination matrices with relative turning percentages for all directions of the junction. To these demand patterns four total demands are applied: 500, 1500, 2500 and 3500 vehicles per hour. First intention was to investigate 4500 and 5500 vehicles per hour too. However, this resulted in approaching links being restrictive instead of the junction design. Because only one approaching lane on a link is investigated and the junction effects should be determined these total demands are not used in the modelling framework. The combination of relative turning percentages with total demands result in absolute origin destination matrices that can be applied to the junction designs. The procedure to form the relative origin destination matrices and absolute origin destination matrices, is elaborated in Appendix C.

### **3.2.3 Network criteria**

The network criteria are already mentioned in the research scope. This research is conducted for urban networks and the related speed limits investigated are 30, 50 and 70 kilometres per hour. Additional network requirement is that the approaching links are set to two kilometres. This seems a long length to calculate the performance of a single junction. However, some combinations of junction designs and traffic demands have an impact that reaches far upstream of the approaching link. Furthermore, a fixed link length is necessary for the explanation of the assessment.

### **3.2.4 Modelling framework**

The static macroscopic junction emission model has to determine results for different junction designs. On these junction designs a combination of junction demand criteria and network criteria is used to generate emission data. Therefore, an extra differentiation is made between the junction

designs on the one hand and input criteria including junction demand criteria and network criteria on the other hand. The components of the modelling framework are summarised in Table 1.

**Table 1: Overview of components in the modelling framework**

Modelling framework subjects	Components	Elements
<b>Junction designs</b>	Junction design variables	Junction design (number of variations) Equal junctions (2) Priority junctions (4) Signalized junctions (10) Roundabout (2)
<b>Input criteria</b>	Junction demand criteria	Total demand (veh/h) Demand pattern 500, 1500, 2500, 3500 All equal, straight ahead, turn, one direction
	Network criteria	Road type Speed limit Approach link length (km) Urban 30, 50, 70 2

### 3.3 Assessment framework

The assessment is performed by comparing the results of the static model with the dynamic model. The goal of the assessment is to include the requirement, that the results of the static junction emission model should produce results that can be used in the decision support tool, into the design of the model. This tool support multi-objective design choices and therefore the best junction design for an input criteria set has to be determined. Due to uncertainties in the model it is possible that the second best junction design is in reality the best option. Therefore, a bandwidth of 5% is included to determine the best option. This results in a list of the best junction design(s) per input criteria set for both models. This is a nominal variable and therefore it is difficult to statistically determine if the junction emission model produces the same results as the existing emission model. Therefore, the junction emission model is also assessed with an ordinal variable to determine if the differences between both models are significant. This ordinal variable is a total rank of all junction designs instead of only the best option(s). Furthermore, it can be necessary to use absolute emission values in the decision support tool. Therefore the absolute emission value, which is a ratio variable, is used to give direction to the improvements of the junction emission model. Next sections describe the exact execution of the assessment.

#### 3.3.1 Best option(s) with 5% bandwidth

Assessing the best option(s) is performed in three steps:

1. Determining the best option(s) with a bandwidth of 5% for both models
2. Compare the results of both models to each other
3. Determine if both models produce equal results for the whole data set or sub sets

The first step is determining the junction design(s) with the lowest emission value per input criteria set for both junction emission models with a bandwidth of 5%. This is executed by determining the junction design with the lowest emission value. After that, all junction design(s) that produce emission values that are maximal 5% higher are also listed. This results in a list of junction design(s) per input criteria set for both models.

Secondly is determined if one (or more) of the listed junction design(s) listed for the static model is listed for the dynamic model too. If this is the case it is called "equal" otherwise it is called "different".

Last step is to determine the percentage of input criteria sets that are listed as equal, as determined in step two, in the whole dataset or sub sets. This is called the 95% requirement. When the percentage equals is lower than 95% the assessment is that the static model produces results that are not useful to compare different junction designs for the decision support tool. This is a strict requirement because both models have uncertainties. This last step is also performed for the sub sets:

- Speed limit: 30 km/h, 50 km/h and 70 km/h
- Demand pattern: all equal, straight ahead, turn and one direction
- Total demand: 500 veh/h, 1500 veh/h, 2500 veh/h, 3500 veh/h, 4500 veh/h and 5500 veh/h

This step results in a table in which for all (sub) sets is shown if the static model produces useful results or not.

### **3.3.2 Ranking all junctions**

Second assessment step is to rank all junctions per input criteria set. With this method the ordinal variable is added to all rows of the dataset for both models. This ordinal variable has to be compared per element of the modelling framework and therefore it is a paired comparison. A paired comparison of an ordinal variable can be executed with an Wilcoxon signed rank test (B. Baarda, Dijkum, & Goede, 2014). With a significance level of 5% determined if the static model produces equal ranking results as the dynamic model. This analysis is performed for the same sub sets as used for the best option(s) with 5% bandwidth assessment.

### **3.3.3 Absolute emission values**

The absolute emission values are compared too. Usually, a comparison test on ratio variable is executed with a T-test. However, the emission results show strong right skewed distribution which causes that the T-test is not suitable and a Wilcoxon signed rank test has to be used (B. Baarda et al., 2014). With a significance level of 5% determined if the static macroscopic junction emission model produces equal absolute results as the dynamic macroscopic junction emission model. This analysis is also performed for the sub sets as used for the best option(s) and the total ranking. One category is added to these sub sets: main junction type. Herewith, the extent to which the overall differences are caused by the modelling of a junction type can be determined. This sub set is not included in the analysis of the ranks because the results of used for that analysis, the actual ranks, are dependent on the performance of other junction types.

## **3.4 Configuration of the dynamic junction emission model**

The dynamic model plays an important role in the research strategy because it is used two times to assess the static model. Therefore, the configuration of the dynamic model is provided in this section.

First configurations are related to the calculation of the emission values with the dynamic model. As seen in the equation in section 2.2.4 the emission is calculated per time interval and link segment.

The time interval for which the emissions are calculated is 5 minutes. Furthermore, each approaching link is divided into link segments of 50 metres.

Other configurations are related to the practical implementation of the model. First one is related to the interaction between the successive link segments. The dynamic network loading model provides traffic information (e.g. density, speed, flow) for each link segment. This traffic state depends on both the amount of vehicles on the segment and the situation upstream and downstream. For example, if a downstream link segment has a decreased average speed due to an increased flow the average speed on the upstream link segment also decreases to some amount already. Even, if it is not necessary to serve the traffic on that link itself. In the dynamic network loading model of OmniTRANS these effects are present as anticipation and relaxation terms. In urban networks these effects seem less present than on rural networks or highways. Therefore, the anticipation and relaxation terms are set for urban networks by using urban link types.

The traffic state on the link segment itself is dependent on the fundamental diagrams for the road type. Parameter that needs to be set for these fundamental diagrams is the speed at capacity. On highways 75% of the speed limit is often used for the speed at capacity. On urban network this factor is difficult to determine but it is assumed that the speed at capacity is a higher percentage of the speed limit. Therefore, the speed at capacity is set to 80% of the speed limit.

Other model configuration is the modelling duration. In some cases of the modelling framework high traffic demands are loaded to small junctions. After some tests with the dynamic model it was found that not all traffic passes the junction in some cases. This means that some traffic remains in the network and their effects on the emission results are not incorporated. To incorporate the effects of all vehicles to the emission results the modelling duration is increased to three hours. All traffic is loaded to the network in the first hour but the model runs for three hours to let all traffic flow out of the network. The modelling duration is increased to three hours because in some cases two hours is still not appropriate.

Last but important configuration is that in this research the emission factors will be based on estimates of the Dutch fleet data of 2015 (Janssen, Okker, & Schuur, 2006). This also counts for the static model.

## 4 Design: static macroscopic emission model

In this chapter the first static model is designed. This design is a simplified traffic situation based model. It is expected that the queue length causes the most differences between different junction designs. The heavy and saturated traffic states are expected to occur at the deceleration phase, which is likely to be equal for all junction designs with the same speed limit. Therefore, the base concept for the static model is to determine the lengths for which traffic uses the 2 kilometres long approaching links in the stop & go traffic state and the free flow traffic state. To determine this stop & go length the reasoning is used that traffic is driving in the stop & go traffic state while queuing and in the free flow traffic state while approaching the queue. Therefore, the queue length per turn is translated into a stop & go length per turn and therewith the emission value per turn is calculated. The calculation of this stop & go length is explained in the next section and model parameters are provided in section 4.2. Finally the turn emission values are added up to form the junction emission value. The junction emission value is calculated by:

$$junction\ emission = \sum_t SG_t \times E_s(sg) \times q_t + (2 - SG_t) \times E_s(ff) \times q_t$$

With:

$SG_t$  = length for which the stop & go traffic state is determined for turn  $t$  (kilometres)

$E_s(sg)$  = stop & go emission factor for speed limit  $s$  (grams per vehicle kilometre)

$E_s(ff)$  = free flow emission factor for speed limit  $s$  (grams per vehicle kilometre)

$q_t$  = load on turn  $t$  (vehicles per hour)

### 4.1 Stop & go length

The stop & go length is calculated in four steps. First, the queue length is calculated per turn, independently of the approach lane configuration. This results in three queue lengths per approaching link for the left, straight ahead and right turning directions. Second step is to determine the queue length for the approach lane configuration. For example, if the junction contains one approach lane for all directions the queue length for that approach lane is the sum of the queue lengths of all three directions. Third step is to determine if the queue length of the approach lanes block each other, called the blocking effect. If the queue length of one approach lane is longer than the approach lane length the queue reaches to the approaching link. This causes that the vehicles that are intended to use the other approach lane cannot reach that approach lane and are in a queue for a longer length. Final step is to translate the queue lengths per approach lane including the blocking effect back to the stop & go length per turn.

#### 4.1.1 Queue length per turn

The queue length per turn is based on the average delay per vehicle for that turn. This delay is calculated by OmniTRANS with the junction module, as explained in chapter two. This delay is multiplied with the load on that turn to determine the total average delay for that turn in hours. It was also considered to use the overflow queue. This is the average number of vehicles per cycle left over at the end of green periods at signals or at the end of acceptable gap periods during gap-acceptance periods. This only considers the queue length of the vehicles that do not pass the junction. However, the other vehicles actually have delay too. Therefore this option is not used for

the queue length and the average delay forms the base for the queue length calculation. This total average delay can be translated into a pseudo situation where the total average delay can be regarded as an average number of queuing vehicles. For example, if the average delay is 0.02 hours per vehicle and the number of vehicles on the turn is 100 the total average delay is 2 hours. The pseudo situation will be that 2 vehicles wait for one hour, while the other 98 vehicles pass the junction without delay. Reasoning back results in an average delay of:  $\frac{2 \times 1 + 98 \times 0}{100} = 0.02 \text{ hours}$ . In this pseudo situation the queued vehicles are in idle traffic state for one hour. However, in reality all vehicles will decelerate and accelerate which is stop & go behaviour.

The average number of queuing vehicles is multiplied with the vehicle length including space between vehicles and this result in the queue length per turn. The equation is:

$$Q_t = d_t \times q_t \times l_{veh}$$

With:

$Q_t = \text{queue length per turn } t \text{ (kilometres)}$

$d_t = \text{average delay per vehicle on turn } t \text{ (hours)}$

$q_t = \text{load on turn } t \text{ (vehicles per hour)}$

$l_{veh} = \text{vehicle length (kilometres)}$

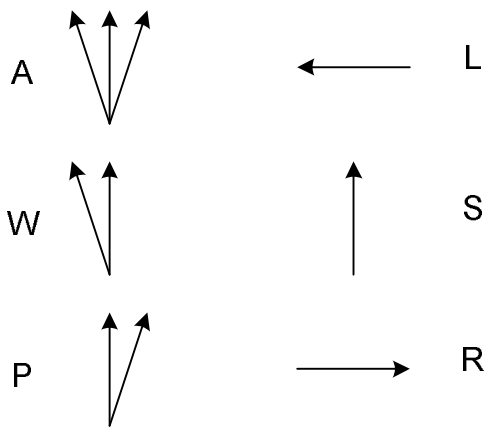
#### 4.1.2 Stop & go length per turn

The second, third and fourth steps are separated steps but are explained together. These steps are elaborated per approach lane arrangement. The second step is to determine the queue length per approach lane. In the modelling framework different approach lane configurations are used. For each configuration the queue length per approach lane is determined. Hereby it is assumed that the traffic using a turning direction with two approach lanes is divided equal over both lanes. The other way around, when turns are combined per approach lane the queue lengths are summed for these turns. Exception is the approach lane arrangement with two lanes: one combined lane for left and straight ahead and one combined lane for right and straight ahead. The division of the straight ahead traffic is dependent on the traffic of the left and right direction. This will be explained at the arrangement itself.

After the calculation of the queue length per approach lane, the blocking effect is included. Hereby is determined if the queue of one approach lane exceeds the approach lane length and therewith blocks the traffic that is intended to use the other approach lane(s). If the blocking effect occurs the queue length of all approach lanes is set to the queue length that causes the block. Actually, this does not mean that the queue length of the blocked approach lane is this large. However, it determines the length on which the traffic is passing the junction in a stop & go traffic state. Therefore a new parameter is introduced which is SG. This is explained as the length on which the traffic passes the junction in the traffic state stop & go, the stop & go length. The final step is to translate the queue length per approach lane to the stop & go length per turning direction.

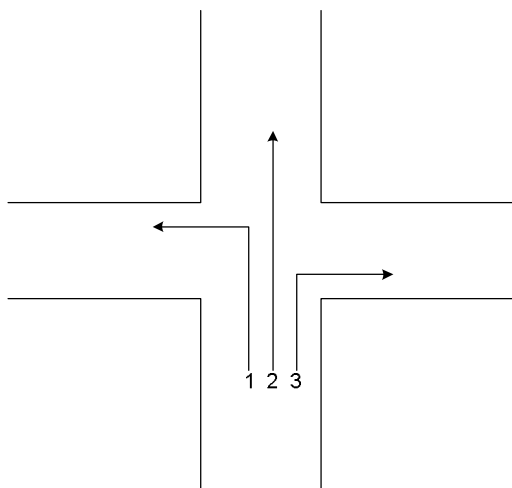


Each approach lane design has a symbol, which is shown in Figure 8. The approach lane designs can be combined too. For example, arrangement "LSR" means a separate approach lane for the left, the straight ahead and the right direction.



**Figure 8: Symbols for approach lane arrangements.**

The arrangements will be explained for one approaching link because the reasoning for the other approaching links is exactly the same. In the explanation the turn are numbered as shown in Figure 9.



**Figure 9: Turn numbers**

The parameter symbols used in the calculation are:

$Q$  = queue length (kilometres)

$SG$  = stop & go length (kilometres)

$l_{app}$  = approach lane length (kilometres)

**Arrangement "A"**

The arrangement has only one approach lane which means that the total queue length is the sum of the three turning queue lengths. Furthermore, no blocking effect occurs because there is only one approach lane. The equation is:

$$Q_A = Q_1 + Q_2 + Q_3$$

Because no blocking effect can occur, the stop & go lengths per turn are:

$$SG_1 = Q_A$$

$$SG_2 = Q_A$$

$$SG_3 = Q_A$$

### **Arrangement "WR"**

This arrangement has a combined approach lane for the left and the straight ahead direction and a separate approach lane for the right direction. The equation is:

$$Q_W = Q_1 + Q_2$$

$$Q_R = Q_3$$

The blocking effect occurs when the longest approach lane queue exceeds the approach lane length. Then both approach lane queues are set to this longest approach lane queue length. And that results in stop & go lengths that are equal for all three turning directions.

$$\text{if } \max(Q_W, Q_R) > l_{app} \rightarrow SG_1 = SG_2 = SG_3 = \max(Q_W, Q_R)$$

$$\text{else } \begin{cases} SG_1 = SG_2 = Q_W \\ SG_3 = Q_R \end{cases}$$

### **Arrangement "LSR"**

This arrangement has separate approach lanes for each turning direction:

$$Q_L = Q_1$$

$$Q_S = Q_2$$

$$Q_R = Q_3$$

The blocking effect occurs when the longest approach lane queue exceeds the approach lane length. Then both approach lane queues are set to this longest approach lane queue length. And that results in stop & go lengths that are equal for all three turning directions.

$$\text{if } \max(Q_L, Q_S, Q_R) > l_{app} \rightarrow SG_1 = SG_2 = SG_3 = \max(Q_L, Q_S, Q_R)$$

$$\text{else } \begin{cases} SG_1 = Q_L \\ SG_2 = Q_S \\ SG_3 = Q_R \end{cases}$$

### **Arrangement "LLSSRR"**

In this arrangement each turning direction has two approach lanes. This means that the queue length per turn is divided over two lanes. Assuming that this division is equal, the queue length per approach lane is half the queue length per turn.

$$Q_L = Q_1/2$$

$$Q_S = Q_2/2$$

$$Q_R = Q_3/2$$

The blocking effect occurs when the longest approach lane queue exceeds the approach lane length. Then both approach lane queues are set to this longest approach lane queue length. And that results in stop & go lengths that are equal for all three turning directions.

$$if \max(Q_L, Q_S, Q_R) > l_{app} \rightarrow SG_1 = SG_2 = SG_3 = \max(Q_L, Q_S, Q_R)$$

$$else \begin{cases} SG_1 = Q_L \\ SG_2 = Q_S \\ SG_3 = Q_R \end{cases}$$

### **Arrangement "LSRR"**

In this arrangement the right turn has two approach lanes. This means that the calculated queue for that turn is divided over two approach lanes. Assuming that this division is equal, the queue length for this approach lane is half the queue length per turn.

$$Q_L = Q_1$$

$$Q_S = Q_2$$

$$Q_R = Q_3/2$$

The blocking effect occurs when the longest approach lane queue exceeds the approach lane length. Then both approach lane queues are set to this longest approach lane queue length. And that results in stop & go lengths that are equal for all three turning directions.

$$if \max(Q_L, Q_S, Q_R) > l_{app} \rightarrow SG_1 = SG_2 = SG_3 = \max(Q_L, Q_S, Q_R)$$

$$else \begin{cases} SG_1 = Q_L \\ SG_2 = Q_S \\ SG_3 = Q_R \end{cases}$$

### **Arrangement "LLSR"**

In this arrangement the left turn has two approach lanes. This means that the calculated queue for that turn is divided over two approach lanes. Assuming that this division is equal, the queue length for this approach lane is half the queue length per turn.

$$Q_L = Q_1/2$$

$$Q_S = Q_2$$

$$Q_R = Q_3$$

The blocking effect occurs when the longest approach lane queue exceeds the approach lane length. Then both approach lane queues are set to this longest approach lane queue length. And that results in stop & go lengths that are equal for all three turning directions.

$$if \max(Q_L, Q_S, Q_R) > l_{app} \rightarrow SG_1 = SG_2 = SG_3 = \max(Q_L, Q_S, Q_R)$$

$$\text{else} \begin{cases} SG_1 = Q_L \\ SG_2 = Q_S \\ SG_3 = Q_R \end{cases}$$

### **Arrangement "LSSR"**

In this arrangement the straight ahead direction has two approach lanes. This means that the calculated queue for that turn is divided over two approach lanes. Assuming that this division is equal, the queue length for this approach lane is half the queue length per turn.

$$Q_L = Q_1$$

$$Q_S = Q_2/2$$

$$Q_R = Q_3$$

The blocking effect occurs when the longest approach lane queue exceeds the approach lane length. Then both approach lane queues are set to this longest approach lane queue length. And that results in stop & go lengths that are equal for all three turning directions.

$$\text{if } \max(Q_L, Q_S, Q_R) > l_{app} \rightarrow SG_1 = SG_2 = SG_3 = \max(Q_L, Q_S, Q_R)$$

$$\text{else} \begin{cases} SG_1 = Q_L \\ SG_2 = Q_S \\ SG_3 = Q_R \end{cases}$$

### **Arrangement "WP"**

As mentioned in the introduction of this chapter this arrangement needs more explanation by determining the queue length per approach lane. This arrangement has one combined approach lane for left and straight ahead and one combined approach lane for right and straight ahead. The straight ahead traffic should be divided over both approach lanes. Hereby it cannot be assumed that half the straight ahead traffic uses the left approach lane and half the straight ahead traffic uses the right lane. This is dependent on the queue lengths of the left turn and the right turn. The assumption is that the straight ahead traffic divides over the two approach lanes in a way that the total of both lanes becomes equal. However, when the left queue is longer than the straight ahead and right queue together all straight ahead traffic uses the right approach lane. The other way around when the right queue is longer than the straight ahead and left queue together all straight ahead traffic uses the left approach lane. The equation is:

$$\text{if } Q_1 > Q_2 + Q_3 \rightarrow \begin{cases} Q_w = Q_1 \\ Q_p = Q_2 + Q_3 \end{cases}$$

$$\text{else if } Q_3 > Q_1 + Q_2 \rightarrow \begin{cases} Q_w = Q_1 + Q_2 \\ Q_p = Q_3 \end{cases}$$

$$\text{else } Q_w = Q_p = \frac{Q_1 + Q_2 + Q_3}{2}$$

The blocking effect occurs when the longest approach lane queue exceeds the approach lane length. Then both approach lane queues are set to this longest approach lane queue length. And that results in stop & go lengths that are equal for all three turning directions. If no blocking effect occurs the

stop & go lengths are dependent on the separate queue length per turn as explained earlier in this paragraph.

$$\text{if } \max(Q_W, Q_P) > l_{app} \rightarrow SG_1 = SG_2 = SG_3 = \max(Q_W, Q_P)$$

$$\text{else if } Q_W > Q_P \rightarrow \begin{cases} SG_1 = Q_W \\ SG_2 = SG_3 = Q_P \end{cases}$$

$$\text{else if } Q_P > Q_W \rightarrow \begin{cases} SG_1 + SG_2 = Q_W \\ SG_3 = Q_P \end{cases}$$

$$\text{else } SG_1 = SG_2 = SG_3 = \frac{Q_P + Q_W}{2}$$

## 4.2 Static model parameters

In this chapter two modelling parameters are introduced: the vehicle length and the approach lane length. Furthermore, a third parameter is used in the static model: the maximum delay per vehicle. For these three parameters values are chosen to use in this model and these are elaborated in this section.

The vehicle length is used to translate the number of vehicles into the stop & go length. The length of the vehicles in a queue is the sum of the length of the vehicles and the space between those vehicles. The standard value for the length of a vehicle in OmniTRANS is 5 metres. Adding space of 1 metre between the vehicles makes a sum of 6 metres per vehicle in the vehicle queue. Because this length is expressed in kilometres the vehicle length becomes:  $l_{veh} = 0.006 \text{ kilometres}$ .

The approach lane length has influence on the blocking effect explained in the foregoing section. For the dynamic model an approach lane length of 100 metres is used as default. To get a fair comparison the approach lane length for the static model is also set to 100 metres. Because this length is expressed in kilometres the approach lane length becomes:  $l_{app} = 0.1 \text{ kilometres}$ .

Last parameter is the maximum delay per vehicle. Because static models can create unrealistic oversaturated situations on junctions and therewith extremely high delays a maximum delay of 300 seconds per vehicle is default for the static model. However, for this research extremely high delays can occur because high demands are loaded to small junction designs. Therefore it is wished to have no delay restriction and this the maximum delay is set to infinite.

## 5 Assess: Assessment I

In this chapter the assessment is performed by applying the results, obtained by applying both models to the modelling framework, to the assessment framework. In section 5.1 the assessment for the best option with 5% bandwidth is provided and in section 5.2 the Wilcoxon signed rank tests for the ranks and absolute values are elaborated together.

### 5.1 Best option with 5% bandwidth

The requirement for the total set and sub sets is that in 95% of the cases one or more junction designs determined as the best option by the static model should be equal to one of the best options determined by the dynamic macroscopic junction emission model. This assessment is executed for the three substances CO<sub>2</sub> shown in Table 2, NO<sub>x</sub> shown in

Table 3 and PM<sub>10</sub> shown in Table 4.

For the total set the static model does not fit the requirement for all three substances. Further point is that for the sub set 500 vehicles per hour the model produces results that fit the requirement for all three substances. Investigating the ranks of these sub sets shows that the dynamic model determines all junction designs as best option. Therefore independent of the static model results, the best option comparison for all input criteria sets result in "equal".

Analysis of the percentages also reveal remarkable points. In the elaboration of this analysis a "low score" means that the percentage equals for a sub set is low and the percentage not equal is high. The opposite is a "high score" which means that the percentage equals for a sub set is high and the percentage not equal is low. Remarkable point is the low score of the sub set 30 km/h for NO<sub>x</sub> compared with the other two speed limits and also compared with the score at 30 km/h for the other two substances. The PM<sub>10</sub> results show a low score for 50 km/h compared with the other to speed limits and also compared with the score at 50 km/h for the other two substances.

**Table 2: Best option with 5% bandwidth assessment for CO<sub>2</sub>.** Red colour means sub set does not satisfy the requirement, green colour means sub set satisfies the requirement. The "equal" and "not equal" represent the percentages of the number of input criteria sets for which the best option(s) are equal and not equal. N is the number of input criteria sets over which the static model is assessed.

Set					
<b>Total (n = 48)</b>	Sub set	<b>Total</b>			
	Equal	87.23%			
	Not equal	12.77%			
<b>Speed Limit (n = 16)</b>	Sub set	<b>30 km/h</b>	<b>50 km/h</b>	<b>70 km/h</b>	
	Equal	87.50%	86.67%	87.50%	
	Not equal	12.50%	13.33%	12.50%	
<b>Total demand (n = 12)</b>	Sub set	<b>500 veh/h</b>	<b>1500 veh/h</b>	<b>2500 veh/h</b>	<b>3500 veh/h</b>
	Equal	100.00%	100.00%	100.00%	45.45%
	Not equal	0.00%	0.00%	0.00%	54.55%
<b>Demand pattern (n = 12)</b>	Sub set	<b>All equal</b>	<b>Straight ahead</b>	<b>Turn</b>	<b>One direction</b>
	Equal	100.00%	75.00%	75.00%	100.00%
	Not equal	0.00%	25.00%	25.00%	0.00%

Table 3: Best option with 5% bandwidth assessment for NO<sub>x</sub>. Red colour means sub set does not satisfy the requirement, green colour means sub set satisfies the requirement. The “equal” and “not equal” represent the percentages of the number of input criteria sets for which the best option(s) are equal and not equal. N is the number of input criteria sets over which the static model is assessed.

Set					
<b>Total</b> (n = 48)	Sub set	<b>Total</b>			
	Equal	70.83%			
	Not equal	29.17%			
<b>Speed Limit</b> (n = 16)	Sub set	<b>30 km/h</b>	<b>50 km/h</b>	<b>70 km/h</b>	
	Equal	37.50%	87.50%	87.50%	
	Not equal	62.50%	12.50%	12.50%	
<b>Total demand</b> (n = 12)	Sub set	<b>500 veh/h</b>	<b>1500 veh/h</b>	<b>2500 veh/h</b>	<b>3500 veh/h</b>
	Equal	100.00%	83.33%	66.67%	33.33%
	Not equal	0.00%	16.67%	33.33%	66.67%
<b>Demand pattern</b> (n = 12)	Sub set	<b>All equal</b>	<b>Straight ahead</b>	<b>Turn</b>	<b>One direction</b>
	Equal	83.33%	66.67%	58.33%	75.00%
	Not equal	16.67%	33.33%	41.67%	25.00%

Table 4: Best option with 5% bandwidth assessment for PM<sub>10</sub>. Red colour means sub set does not satisfy the requirement, green colour means sub set satisfies the requirement. The “equal” and “not equal” represent the percentages of the number of input criteria sets for which the best option(s) are equal and not equal. N is the number of input criteria sets over which the static model is assessed.

Set					
<b>Total</b> (n = 48)	Sub set	<b>Total</b>			
	Equal	79.17%			
	Not equal	20.83%			
<b>Speed Limit</b> (n = 16)	Sub set	<b>30 km/h</b>	<b>50 km/h</b>	<b>70 km/h</b>	
	Equal	87.50%	62.50%	87.50%	
	Not equal	12.50%	37.50%	12.50%	
<b>Total demand</b> (n = 12)	Sub set	<b>500 veh/h</b>	<b>1500 veh/h</b>	<b>2500 veh/h</b>	<b>3500 veh/h</b>
	Equal	100.00%	91.67%	83.33%	41.67%
	Not equal	0.00%	8.33%	16.67%	58.33%
<b>Demand pattern</b> (n = 12)	Sub set	<b>All equal</b>	<b>Straight ahead</b>	<b>Turn</b>	<b>One direction</b>
	Equal	100.00%	58.33%	66.67%	91.67%
	Not equal	0.00%	41.67%	33.33%	8.33%

## 5.2 Wilcoxon signed rank test

The results of the Wilcoxon signed rank tests for the ranks and for the absolute emission values are provided together and shown in Table 5 for CO<sub>2</sub>, Table 6 for NO<sub>x</sub> and

Table 7 for PM<sub>10</sub>. For the total data set the only equal score is achieved for the absolute NO<sub>x</sub> values. Furthermore, equal scores for all three substances are only achieved by the rank sub sets 2500 and 3500 vehicles per hour and by the absolute sub set 70 km/h. Differences occur between the results of ranks and absolute values and also between the results of the three substances.

Table 5: Wilcoxon signed rank test for CO<sub>2</sub>. Red means that the static model scores significant different than the dynamic model. Green means that both models score equal based on this test. N is the number of combinations of junction designs and input criteria sets for which the Wilcoxon signed rank test is executed.

Set	Rank/Absolute	(Sub)set			
<b>Total</b> (n = 864)	Rank	Total			
	Absolute	Total			
<b>Speed limit</b> (n = 288)	Rank	30 km/h	50 km/h	70 km/h	
	Absolute	30 km/h	50 km/h	70 km/h	
<b>Total demand</b> (n = 216)	Rank	500 veh/h	1500 veh/h	2500 veh/h	3500 veh/h
	Absolute	500 veh/h	1500 veh/h	2500 veh/h	3500 veh/h
<b>Demand pattern</b> (n = 216)	Rank	All equal	Straigh ahead	Turn	One direction
	Absolute	All equal	Straigh ahead	Turn	One direction
<b>Main junction type</b> (n = 216)	Absolute	Equal junctions	Priority junctions	Signalized junctions	Roundabouts

Table 6: Wilcoxon signed rank test for NO<sub>x</sub>. Red means that the static model scores significant different than the dynamic model. Green means that both models score equal based on this test. N is the number of combinations of junction designs and input criteria sets for which the Wilcoxon signed rank test is executed.

Set	Rank/Absolute	(Sub)set			
<b>Total</b> (n = 864)	Rank	Total			
	Absolute	Total			
<b>Speed limit</b> (n = 288)	Rank	30 km/h	50 km/h	70 km/h	
	Absolute	30 km/h	50 km/h	70 km/h	
<b>Total demand</b> (n = 216)	Rank	500 veh/h	1500 veh/h	2500 veh/h	3500 veh/h
	Absolute	500 veh/h	1500 veh/h	2500 veh/h	3500 veh/h
<b>Demand pattern</b> (n = 216)	Rank	All equal	Straigh ahead	Turn	One direction
	Absolute	All equal	Straigh ahead	Turn	One direction
<b>Main junction type</b> (n = 216)	Absolute	Equal junctions	Priority junctions	Signalized junctions	Roundabouts



Table 7: Wilcoxon signed rank test for PM<sub>10</sub>. Red means that the static model scores significant different than the dynamic model. Green means that both models score equal based on this test. N is the number of combinations of junction designs and input criteria sets for which the Wilcoxon signed rank test is executed.

Set	Rank/Absolute	(Sub)set			
<b>Total</b> (n = 864)	Rank	Total			
	Absolute	Total			
<b>Speed limit</b> (n = 288)	Rank	30 km/h	50 km/h	70 km/h	
	Absolute	30 km/h	50 km/h	70 km/h	
<b>Total demand</b> (n = 216)	Rank	500 veh/h	1500 veh/h	2500 veh/h	3500 veh/h
	Absolute	500 veh/h	1500 veh/h	2500 veh/h	3500 veh/h
<b>Demand pattern</b> (n = 216)	Rank	All equal	Straigh ahead	Turn	One direction
	Absolute	All equal	Straigh ahead	Turn	One direction
<b>Main junction type</b> (n = 216)	Absolute	Equal junctions	Priority junctions	Signalized junctions	Roundabouts

### 5.3 Conclusion

The assessment shows that:

- The static model does not meet the 95% requirement for any substance, only for some sub sets.
- The static model does meet the 95% requirement for all substances for 500 vehicles per hour.
- The static model show differences in results between speed limits for the best option with 5% bandwidth assessment.
- The static model statistically models a different total rank than the dynamic model. Again only for some sub sets the rank is not significantly different.
- The static model only determines equal absolute values for NO<sub>x</sub>. However, most sub sets still show significant differences.

Overall conclusion is that for all three substances the static model does not meet the 95% requirement. However, the results of the substances show differences between them in percentages for the sub sets. Especially, the speed limits show differences in percentages. In addition the results of the Wilcoxon signed rank tests show mostly differences between the ranks of the models. And the same fact counts for the absolute emission values for sub sets of all substances.

## 6 Explain: Explanation of differences in assessment I

In this chapter the results of the assessment are analysed and explained. First, the difference between the assessments of the substances are explained. Second, the differences between the speed limits is elaborated. Third, the differences in the Wilcoxon signed rank tests are elaborated. Finally, the 100% score of all substances for the sub set 500 vehicles per hour is elaborated. Two possible analysis directions can be used. The first direction is the analysis of the differences between the emission calculation methods of the models. The second direction is the analysis of the differences in traffic performance which is used for the calculation of the emissions in both models.

### 6.1 Differences between substances

Differences between substances occur for the assessments results which is remarkable because these emission results are all based on the same junction traffic performances. These are average speed per link segment for the dynamic model and the stop & go length for the static model. This means that the differences of emission results between the substances are caused after the calculation of these traffic performances, in the emission calculation. The difference in the emission calculations between the dynamic and the static model are the incorporation of the number of traffic states. The dynamic model incorporates all four traffic states, free flow, heavy, saturated and stop & go, in the emission calculation. On the other hand, the static model incorporates only free flow and stop & go to calculate the emissions. The effect of this difference is shown by explaining the calculation of the emission results for both models.

The static model only uses free flow and stop & go traffic states for the determination of the emission values. For the calculated stop & go length, the stop & go traffic state and associated emission factor is used. For the approaching traffic the free flow traffic state and associated emission factor is used. The emission factors for most speed limits and substances show that the emission factor for stop & go is higher than the emission factor for free flow. This causes that an increasing stop & go length results in higher emission values. In Figure 10 this means that situation 2 has a higher emission value than situation 1. The only exceptions are the emission factors for NO<sub>x</sub> at a speed limit of 30 kilometres per hour. For this emission factor set the emission factor for stop & go is lower than the emission factor for free flow. This causes that an increasing stop & go length results in lower emission values. In Figure 10 this means that situation 2 has lower emission values than situation 1. Overall the emission values of the static model are directly related and linear to the stop & go length.

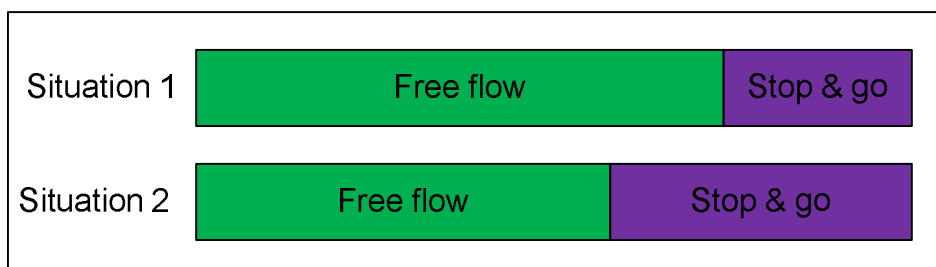


Figure 10: Stop & go length on approaching link for two situations

The dynamic model uses all four traffic states to determine the emission values. The effect and difference with the static model is elaborated by two remarkable facts identified in the assessment. The first one is the difference between the percentages equal and not equal at 30 kilometres per

hour between the substances, shown again in Table 8. On the one hand CO<sub>2</sub> and PM<sub>10</sub> show high percentages equal and on the other hand NO<sub>x</sub> shows a low percentage equal.

**Table 8: Percentages equal and not equal at best option with 5% bandwidth assessment at 30 km/h**

Substance	CO <sub>2</sub>	NO <sub>x</sub>	PM <sub>10</sub>
<b>Equal</b>	87.50%	37.50%	87.50%
<b>Not equal</b>	12.50%	62.50%	12.50%

This difference is explained by an example of this sub set. For this example, the results of four signalized junction designs (301, 302, 303 and 304, see Appendix C) are analysed. Furthermore, the junction demand criteria 2500 vehicles per hour and the turn traffic demand pattern are used.

First step in the dynamic emission calculation is the determination of the traffic states. For this analysis for each junction design the ratio between the traffic states is determined. This ratio is weighted to the number of vehicles using the link. This results in percentages of traffic states in which vehicles passed the junction. The results are shown in Table 9. Junction design 301 shows a high stop & go percentage while the others are lower and more equal to each other. Main difference between those junction designs occur at the saturated traffic state. The percentages at the heavy traffic state are more equal. Striking point is that the heavy and saturated traffic states show no relation with the stop & go traffic state. For example, junction design 301 has the highest stop & go percentage but the lowest saturated percentage. And the saturated percentages of junction designs 302 and 303 are different while the stop & go percentages are about equal.

**Table 9: Weighted traffic states percentages for junction demand criteria 2500 vehicles per hour and turn demand pattern at 30 km/h**

Junction design	Free flow	Heavy	Saturated	Stop & Go
<b>301</b>	52.49%	0.99%	3.31%	43.21%
<b>302</b>	73.48%	0.82%	8.82%	16.88%
<b>303</b>	70.38%	0.84%	12.02%	16.67%
<b>304</b>	71.65%	1.34%	7.55%	19.45%

The traffic states are used to determine the emission values of the junction designs by the associated emission factors and these results are used to determine the rank of the junction designs. An overview of the ranks is shown in Table 10. In this table, only the rank between the four used junction designs is provided. For this rank, the junction design with the lowest emission value scores a 1 and the junction design with the highest emission values scores a 4.

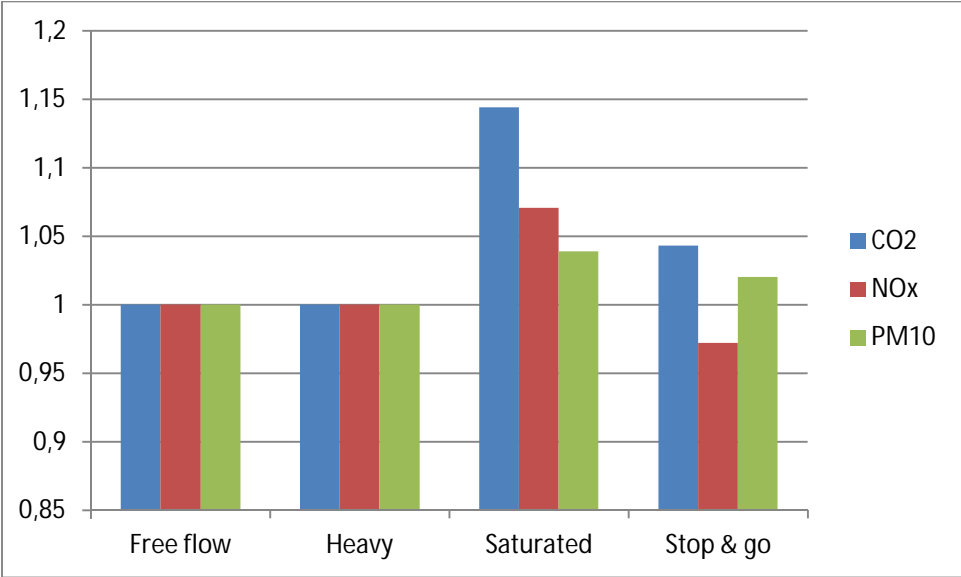
**Table 10: Ranks for junction demand criteria 2500 vehicles per hour and turn demand pattern at 30 km/h**

Dynamic	301	302	303	304	Static	301	302	303	304
<b>CO<sub>2</sub></b>	3	2	4	1	CO <sub>2</sub>	4	3	1	2
<b>NO<sub>x</sub></b>	1	3	4	2	NO <sub>x</sub>	1	2	4	3
<b>PM<sub>10</sub></b>	1	3	2	4	PM <sub>10</sub>	4	3	1	2

Despite the fact that the calculations of the emission values of the three substances are based on the same junction traffic performance, the ranks are different for all three substances. The static model

produces the same ranks for CO<sub>2</sub> and PM<sub>10</sub> while the rank for NO<sub>x</sub> is exactly the opposite. This is caused by the lower emission factor for stop & go compared with free flow at 30 kilometres per hour. For one of the other speed limits the three ranks of the static model are exactly equal.

The difference in ranks of the dynamic model is explained by the difference between the emission factors sets. These difference are displayed by the indexed emission factors, shown in Figure 11. The emission factors are indexed comparing them to the free flow emission factors. The figure shows that the heavy traffic state has an index of 1 for all substances. This means that the heavy emission factor is the same as the free flow emission factor. On its turn, this means that the heavy traffic state does not change the emission value compared to a free flow traffic state. However, the saturated traffic state has a higher index for all three substances which means that the presence of this traffic state increases the emission value compared with the free flow. The stop & go traffic state shows that the emission factors for CO<sub>2</sub> and PM<sub>10</sub> have an increasing effect, while the NO<sub>x</sub> emission factor has a decreasing effect (compared with a free flow traffic state).



**Figure 11: Indexed emission factors (indexed to free flow emission factor) per traffic state at 30 km/h for CO<sub>2</sub>, NO<sub>x</sub> and PM<sub>10</sub>**

Combining the traffic state percentages in Table 9 and the indexed emission factors in Figure 11 explains the differences in the ranks. The rank for CO<sub>2</sub> (Table 10) shows that the junction design 303 scores the lowest ranking, even while junction design 301 has a far higher percentage of stop & go. This is the result of the lower saturated percentage for junction design 301 compared to junction design 303. Looking at the indexed emission factors, the stop & go emission factor has less influence on the emission value than the saturated emission factor. Junction design 303 has a higher saturated percentage than junction design 301 which declares the lower rank for junction design 303. Further analysis shows that the other two junction designs (302 and 304) have higher saturated percentages than junction design 301 too. However, in contrast to junction design 303 these junction design have a higher rank score which means lower emission values. For these junction designs the difference between the stop & go percentages is not removed by the differences between the saturated percentages because these percentages are have smaller differences compared with junction design 301. For NO<sub>x</sub> and PM<sub>10</sub> an equal analysis can be described which results in different results and ranks.

Herewith is shown that the differences between the ratios of the four emission factors cause totally different results that are not linear such as the results of the static model.

For other speed limits the emission factor ratios are actually different. The analysis of this example is also applicable to other junction designs, junction demand criteria and network criteria. However different results are achieved because the calculation contains different emission factor ratios per substance and speed limit which are applied to different ratios of traffic states per junction design. Concluding can be stated that the heavy and saturated traffic states have a reasonable influence on the emission results and thus the rank of the junction designs.

## **6.2 Differences in speed limits**

The junction traffic performances that are used for the calculation of the emissions are a possible explanation differences between the assessment results of the speed limits. These junction traffic performances are different for the static model and the dynamic model. The average delay per vehicle is used for the static model and the average speed is used for the dynamic model. To compare these junction performances a volume weighted average speed is used for the dynamic model. The calculation of this average speed is provided in Appendix D.

### **6.2.1 Comparison of traffic performance per speed limit**

Looking at the average traffic performance curves, striking point is that the static delay shows no differences between the speed limits (Figure 12). In this figure only one delay curve is shown because these are exactly equal for all three speed limits. This is explained by the calculation of the delay at the static model. This delay calculation is dependent on the lane capacity and on its turn the lane capacity is dependent on the design of the junction, turning direction and the load on the turns. A parameter for speed is not included in this calculation.

In contrast, the dynamic traffic performance curve does show differences for different speed limits. If the speed limit is higher, the average speed curve descends steeper at low total demands. Furthermore, the average speed decreases relatively further at higher speed limit. The average speed limit curve at 30 km/h decreases from 30 km/h to 24 km/h which is a decrease of 20%. However the average speed on 50 km/h is higher at 3500 vehicles per hour (36 km/h) it is a decrease of 28%. At 70 km/h this decrease is 36%. This seems logical because at higher speed limits, a vehicle has to decelerate more due to the geometrical limits of the junction and a lower average speed and a higher delay would be a logical result of this deceleration. However, this higher delay is not present at the static model results. Based on this analysis a tentative conclusion is that the static model underestimates the delay at high speed limits or overestimates the delay at low speed limits.

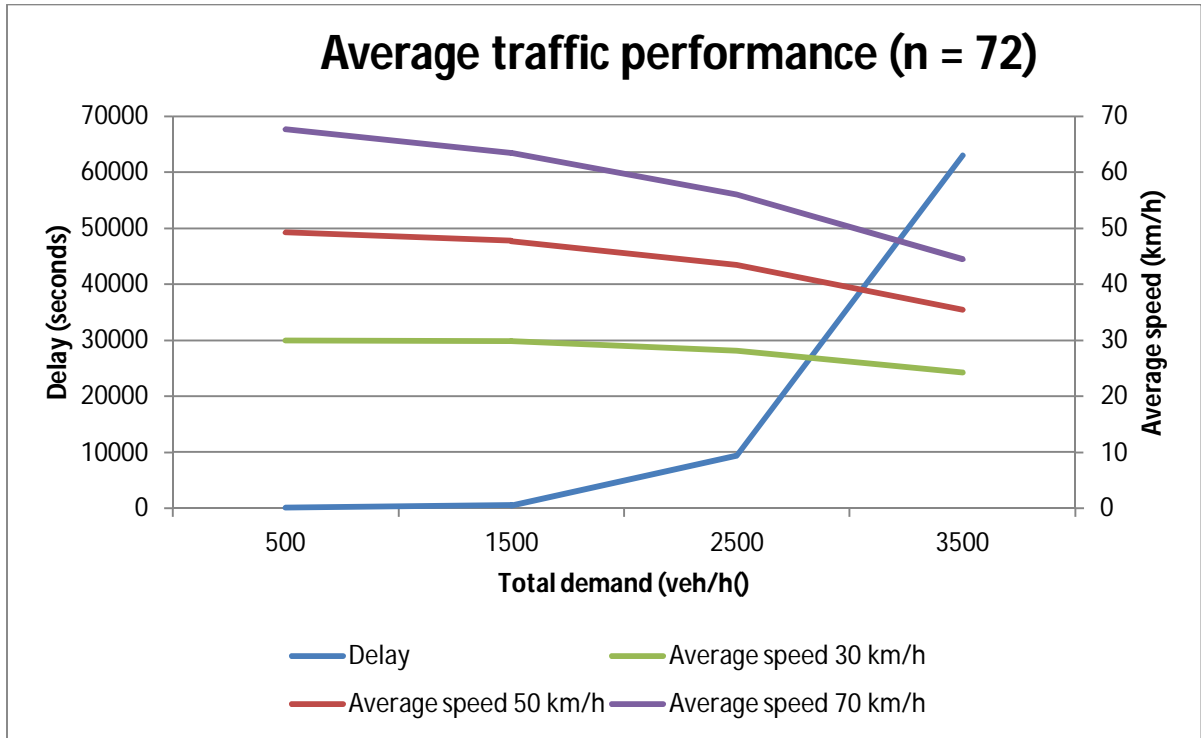


Figure 12: Average delay and average speed per speed limit. Blue line in the graph represents the average delay for the all three speed limits of the static model (connected to the left axis). The other lines represent the weighted average speed per speed limit for the dynamic model (connected to the right axis).

Question is, what the influence of the conclusion drawn before is. Therefore, the effects of the average speed on the emission values is further investigated. This is performed by use the average speed – speed limit ratio on which the emission calculation at the dynamic model is based. Figure 13 shows the average speed – speed limit ratio curves for the three speed limits averaged over all junction designs and demand patterns. The background colour shows in which traffic state this ratio is located for the different total demands. At the first three total demands of the average speed – speed limit ratio at 30 km/h, the curve stays in the free flow traffic state. The 50 km/h curve stays in the free flow traffic state for total demands of 500 and 1500 vehicles per hour. However, at 2500 vehicles per hour the average speed is in the heavy traffic state. The 70 km/h curve even becomes in the saturated traffic state at 2500 vehicles per hour. Despite the fact that these curves are based on average speeds, this is a first indication that the emission values vary per speed limit.

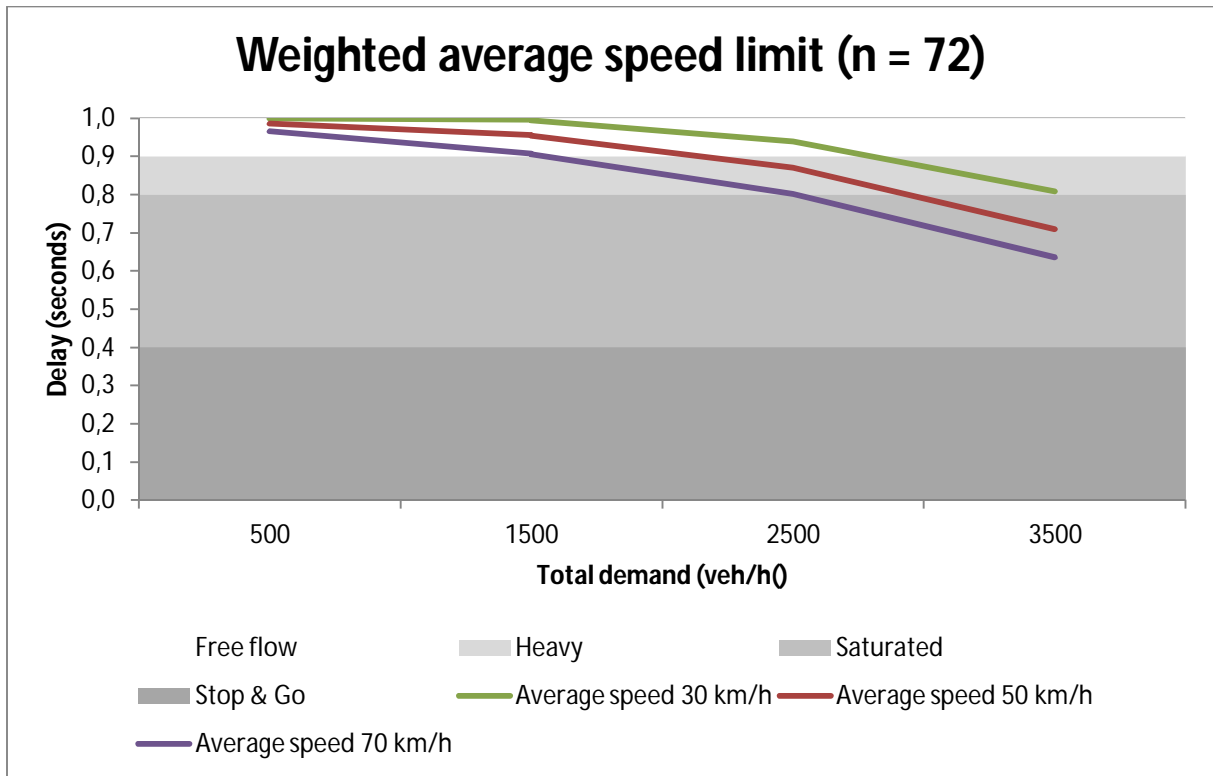


Figure 13: Average speed - speed limit ratio per speed limit averaged over all junction designs and demand patterns

### 6.3 Absolute differences

The assessment showed that the static model significantly differ for the absolute values for CO<sub>2</sub> and PM<sub>10</sub>. To explain these differences the average results of the two models are compared per substance. In Figure 14, Figure 15 and Figure 16 the average emission values are shown for respectively CO<sub>2</sub>, NO<sub>x</sub> and PM<sub>10</sub>. These graphs show that at 3500 vehicles per hour the static model produces higher emission values than the dynamic model. For the other total demands the graphs are more equal. Remarkable is that the Wilcoxon signed rank tests actually show equal results for total demands of 3500 vehicles per hour. This can be explained by the method of the Wilcoxon signed rank test. Difference between the emission results is made pair wise. The largest of the sum of the negative differences or the sum of the positive differences is determinative for the outcomes of the test. The emission values can result in a relatively low sum of differences due to the differences in ranking of both models.

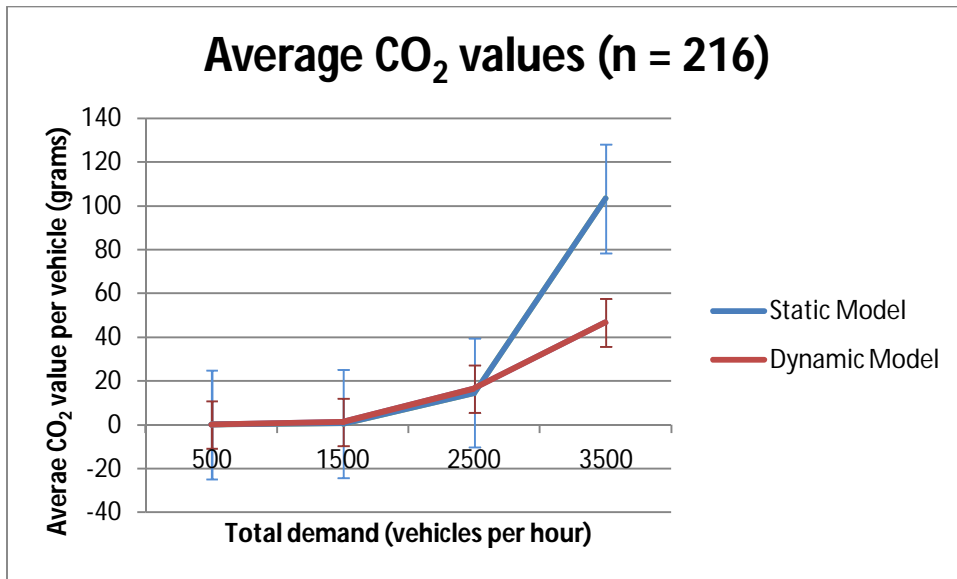


Figure 14: Average CO<sub>2</sub> value per vehicle. The vertical lines show the standard deviation of the emission values. N is the number of records over whom the CO<sub>2</sub> value is averaged. This number is a combination of all junction designs, demand patterns and network criteria.

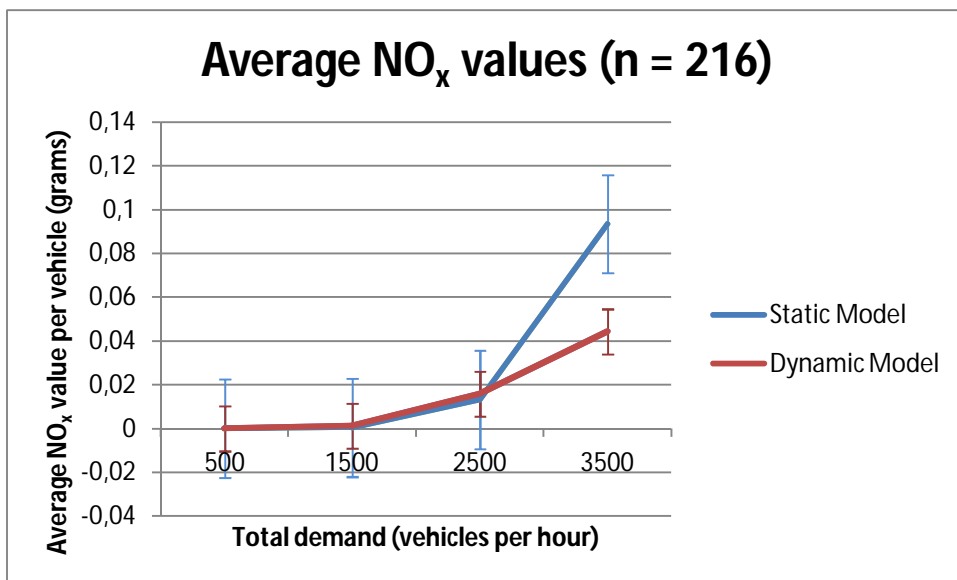


Figure 15: Average NO<sub>x</sub> value per vehicle. The vertical lines show the standard deviation of the emission values. N is the number of records over whom the NO<sub>x</sub> value is averaged. This number is a combination of all junction designs, demand patterns and network criteria.



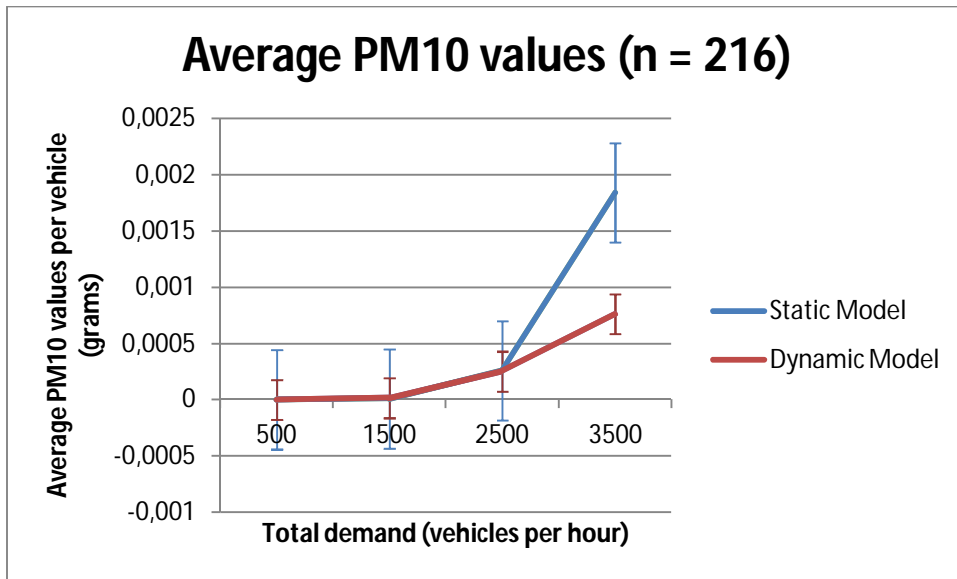


Figure 16: Average PM<sub>10</sub> value per vehicle. The vertical lines show the standard deviation of the emission values. N is the number of records over whom the PM<sub>10</sub> value is averaged. This number is a combination of all junction designs, demand patterns and network criteria.

## 6.4 All best options

Further shown in the assessment is that the dynamic model determines all junction designs as best option for a total demand of 500 vehicles per hour. This results in a 100% score for the best option with 5% bandwidth assessment because all junction designs determined as best option by the static model are equal to one of the best options determined by the dynamic model. The dynamic model determines all junction designs as best option because the low junction demand does not cause such delay that the average speed on a link segment results in another traffic state than free flow, for any junction design. However, the model does determine delay due to the junction design. Question is why this does not causes other traffic states? The free flow traffic state ranges between 100% and 90% of the speed limit due to the borders of the traffic states determined in chapter 2. Which means that if the average speed on a link segment drops below 90% of the speed limit, the traffic state changes. However, the delay caused by a demand of 500 vehicles per hour does not decrease the average speed on a link segment to a lower value than 90% of the speed limit. Therefore, all traffic passes the junction in a free flow traffic state and no differences are determined between junction designs causing all junction designs are ranked as best option.

## 6.5 Conclusion

The goal of the assessment and the explanation of the assessment results was to identify improvement directions to the static model. The conclusion of this chapter is that the static model can be improved by incorporating all four traffic states into the emission calculation. In addition, the emission values of high total demands should be lowered according to the analysis of the averages. Furthermore, difference between traffic performances in speed limits is a possible improvement direction. The execution of these improvements is elaborated in the next chapter.

## 7 Design: Improvements for the static model

The challenge to improve the static model is to incorporate all four traffic states into the emission calculation method of this model and lower the emission values at high total demands. The difference between the speed limits is not tried to improve on its own but, it is tried to include in the improvement in the four traffic states.

To follow the analysis leading to the incorporation of the traffic states it is important to understand the effects of the traffic states on the emission value. If traffic passes a junction design with no delay, it passes the junction in the free flow traffic state. If delay increases on a junction design due to increasing junction demand, the emission value changes due to the other traffic states than free flow. In case of the static model this traffic state is stop & go. In case of the dynamic model these are heavy, saturated and stop & go. The values of the heavy, saturated and stop & go traffic states also depend on the junction design. Different junction designs result in different delays causing different ratios of traffic states. With this explanation is tried to explain that the difference between the emission values of the junction designs is determined by the presence of the non-free flow traffic states. Therefore, the analysis in this chapter focuses on the traffic states: heavy, saturated and stop & go.

To incorporate the heavy and saturated traffic states into the static model two question have to be answered:

1. What is the percentage of the stop & go traffic state in the dynamic model and how is it related to the percentage stop & go of the static model?
2. What is the ratio between the heavy, saturated and stop & go traffic states and how can this ratio be incorporated in the static model?

### 7.1 Stop & go percentage

The stop & go percentages are determined in different ways for both models. For the static model it is the percentage of stop & go length per turn on a two kilometre link, averaged over the twelve turns. This leads to a stop & go percentage. For the dynamic model, the weighted stop & go percentage is used. The percentages are averaged for the total dataset, per speed limit and per total demand. In Table 11 the results are shown for the static, the improved static model (which is the result of this analysis in this section) and the dynamic model. The results show that the static model has higher stop & go percentages for all sets. Furthermore, the percentages for the dynamic model differ per speed limit. However, this effect is not present at the static model percentages. Last point is that the main difference between the percentages is made by 3500 vehicles per hour were the static model has far higher stop & go percentages. This also explains the higher average emission values at this total demand. So the improvement solves (a part) of this difference.

The difference between the percentages of the speed limits are dealt with later. The higher percentage stop & go, especially at 3500 vehicles per hour is dealt with by scrutinising the stop & go length calculation of the static model. This led to two improvements:

1. Set a maximum queue length based on the number of vehicles using the turn.
2. Improvement of the blocking effect calculation.

The first improvement is identified by analysing the queue length per turn. In some cases this queue length was longer than the number of vehicles using that turn can cause. The reason for this is that in some cases the delay values reached higher than one hour per vehicle. Even while the modelling duration is one hour. This resulted in vehicles taken more than one time into account for the queue length determination. On its turn resulting in longer queue lengths than possible according to the number of vehicles. This problem can be solved in two ways. The maximum delay per vehicle is set to one hour or the maximum queue length per turn is set to the maximum number of vehicles using that turn. It is chosen to use the last one.

Second improvement concerns the blocking effect. In the current static model the blocking effect occurs when the longest queue length exceeds the approach lane length. In that case all stop & go lengths for that link are set to this longest queue length. However, when a queue length of another turn exceeds the approach lane length too this will increase the total queue length on the approaching link too. Both principles are shown in Figure 17.

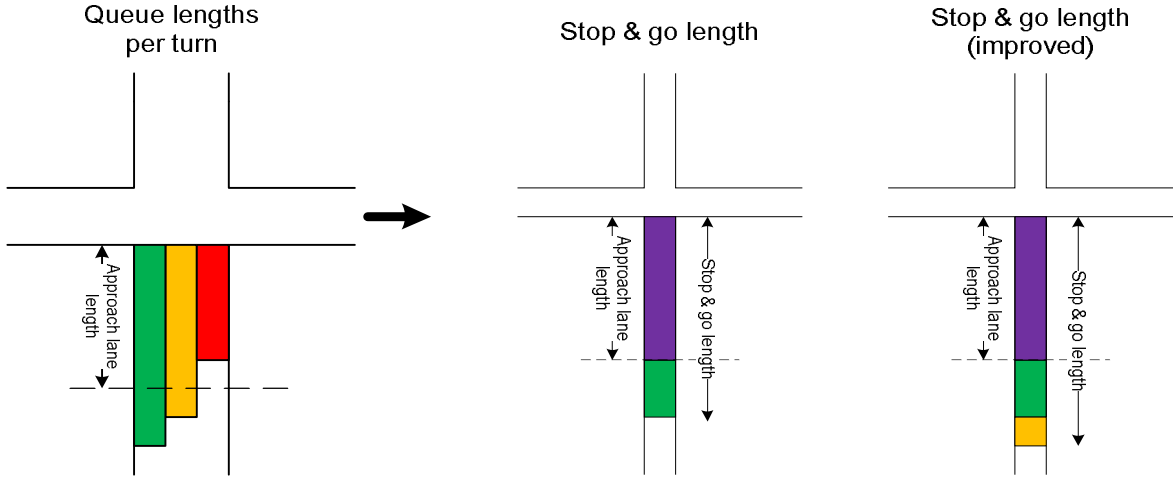


Figure 17: From queue lengths per turn to a stop & go length

Both improvements, mentioned in the begin of this section, are implemented in the static model and the stop & go percentages are calculated again. This leads to the results shown in Table 11. In contrast to the foregoing results, the static model has lower stop & go percentages than the dynamic model. However, the differences are smaller.

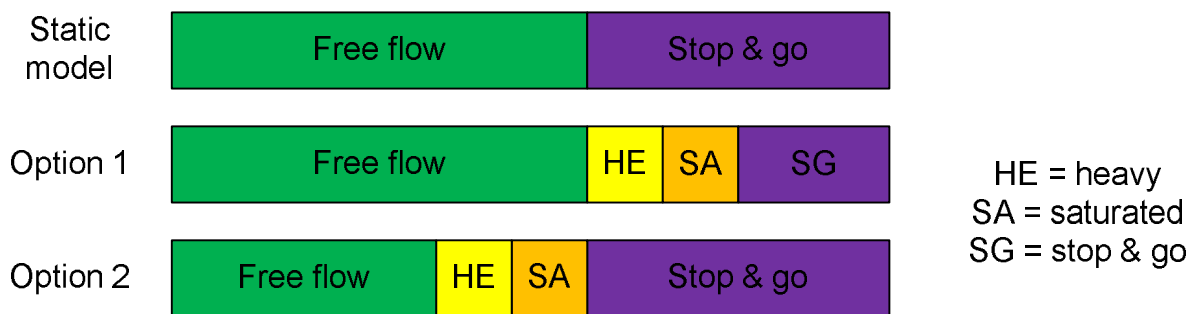
Table 11: Stop & go percentages before and after queue length improvements

Set	Model	Stop & go percentages per (sub) set			
<b>Total</b>		<b>Total</b>			
	Static	14.67%			
	Improved	7.49%			
	Dynamic	9.62%			
<b>Speed limit</b>		<b>30 km/h</b>	<b>50 km/h</b>	<b>70 km/h</b>	
	Static	14.67%	14.67%	14.67%	
	Improved	7.49%	7.49%	7.49%	
	Dynamic	6.31%	10.56%	11.99%	
<b>Total demand</b>		<b>500 veh/h</b>	<b>1500 veh/h</b>	<b>2500 veh/h</b>	<b>3500 veh/h</b>
	Static	0.09%	0.40%	11.53%	46.65%

	Improved	0.09%	0.39%	5.35%	24.14%
	Dynamic	0.00%	0.68%	10.21%	27.60%
<b>Demand pattern</b>	<b>All equal</b>		<b>Straight ahead</b>	<b>Turn</b>	<b>One direction</b>
	Static	14.69%	11.58%	15.64%	16.77%
	Improved	6.45%	6.49%	8.15%	8.88%
	Dynamic	6.93%	10.77%	12.28%	8.51%

## 7.2 Heavy, saturated and stop & go traffic states

After the improvement for the stop & go traffic state, the other two traffic states are included. Two ways of including the heavy and saturated traffic states are considered. The first one is to determine the ratio of the non-free flow traffic states of the dynamic model and apply this to the stop & go traffic state of the dynamic model. In this case parts of the stop & go percentages are assigned to the heavy and saturated traffic state (see Figure 18, option 1). However, the results of the foregoing section showed that the stop & go percentages of the static model are already little lower than the stop & go percentages of the dynamic model. Assigning parts of this percentage to other traffic states even lower the stop & go percentage of the static model. Therefore, the heavy and saturated traffic states are added to the stop and go traffic state (see Figure 18, option 2).



**Figure 18: Options for including heavy and saturated traffic state into the static model**

To add the heavy and saturated traffic state to the stop & go traffic state, it is determined for which length these traffic states should be added. This can be performed by make this length dependent, on the stop & go traffic state (which is already determined). However, the heavy and saturated traffic states show no relation with the stop & go traffic state (as already mentioned in section 6.1). Investigation learned that these traffic states are more related to the network performance. Therefore, it is tried to find junction performance measures of the static model which are related to the heavy and saturated percentages of the dynamic model, because junction performances are more related to the network level. The percentages can be translated into a part of the link in which the vehicles pass the junction in the heavy or saturated traffic state. With the link length of 2 kilometres, these percentages can be translated into the link part length per traffic state.

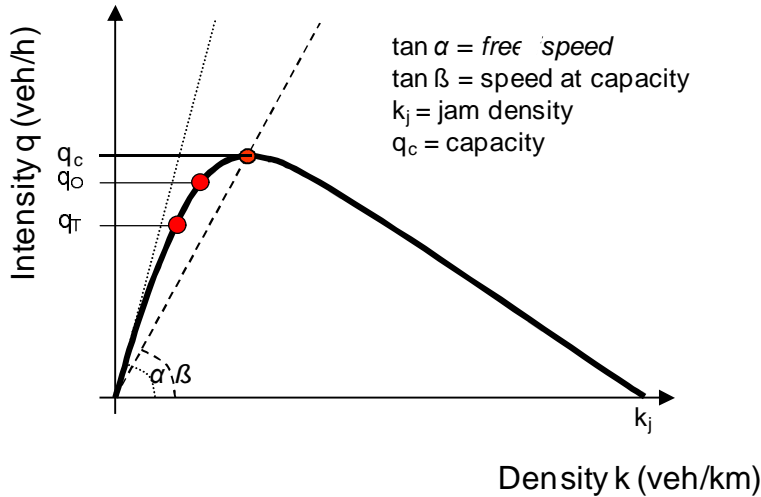
First the current percentages of the heavy and saturated traffic states of the dynamic model are analysed. The result is shown in Table 12. These heavy and saturated percentages are determined the same way as the stop & go percentages in foregoing section. The heavy traffic state percentages are lower and less different than the saturated percentages. This is explained by the traffic state borders (see Figure 4 in section 2.2.4). The heavy traffic state is determined by average speeds between 80% and 90% of the speed limit while the saturated traffic state is determined by average speeds between 40% and 80% of the speed limit. The saturated traffic states has a wider range which

explains the higher percentages. Interesting fact is that the saturated percentages for the demand patterns straight ahead, turn and one direction are higher all three than the saturated percentage for the all equal demand pattern. The difference between the all equal pattern on one hand and the other three patterns on the other hand is that the other three patterns have 1 or 2 approaching links with higher loads. The one direction demand pattern has a approaching link with even higher loads. However, the percentage saturated is not higher than those for the straight ahead and turn demand patterns.

**Table 12: Heavy and saturated percentages**

<b>Set</b>	<b>Traffic state</b>	<b>Percentage</b>			
<b>Total</b>		<b>Total</b>			
	Heavy	0.39%			
	Saturated	2.42%			
<b>Speed limit</b>		<b>30 km/h</b>	<b>50 km/h</b>	<b>70 km/h</b>	
	Heavy	0.33%	0.31%	0.54%	
	Saturated	3.83%	1.74%	1.69%	
<b>Total demand</b>		<b>500 veh/h</b>	<b>1500 veh/h</b>	<b>2500 veh/h</b>	<b>3500 veh/h</b>
	Heavy	0.00%	0.04%	0.40%	1.12%
	Saturated	0.00%	0.17%	1.96%	7.55%
<b>Demand pattern</b>		<b>All equal</b>	<b>Straight ahead</b>	<b>Turn</b>	<b>One direction</b>
	Heavy	0.23%	0.40%	0.40%	0.55%
	Saturated	0.97%	2.87%	2.96%	2.87%

This is explained by analysing the fundamental diagram, forming the base for the traffic performance calculations on each link segment. A standard fundamental diagram is shown in Figure 19. The two extra intensity dots are for the maximum load on an approaching link for the one direction pattern  $q_0$  and for the turn pattern  $q_T$ , which can also count for the straight ahead pattern. A high intensity on the approaching link causes the point ( $q_0$  or  $q_T$ ) will be closer to the capacity ( $q_c$ ). This already causes that the average speed ( $\tan \beta$ ) is lower. Furthermore, if the capacity drops due to the junction demand and junction design the average speed for the one direction pattern also drops further than the average speed for the turn pattern. This lower average speed is related to the traffic state. This explains the higher saturated percentages for the straight ahead, turn and one direction pattern compared with the all equal pattern. Therefore, the saturated percentage is dependent on the maximum load on one of the approaching links. The question still rises why the one direction pattern does not have a higher saturated percentage. This is caused by the loads on the other approaching links (the junction demand sets). In case of the straight ahead and turn pattern two approaching lanes have the highest load. However, the one direction pattern has only one approaching link with the maximum load. This means that an average junction performance measure is also determinative for the heavy and saturated percentages.



**Figure 19: Fundamental diagram**

The maximum load on one of the approaching links and the weighted load capacity ratio are further investigated. The weighted load capacity ratio is the average load capacity ratio weighted for the number of vehicles per turn. Because the load on the link is independent of the link characteristics this variable is supplemented with the critical load capacity ratio. This is the highest load capacity ratio for one of the approaching links.

Visual analysis in combination with a correlation test is used to analyse the effect of these junction performance measures. The visual analysis starts with scatter plots where the heavy and saturated percentages are plotted against the static model performance measures. These scatter plots are provided in Appendix E. These plots show that the weighted load capacity ratio and the maximum load on one of the links seem to have the most relation with the heavy and saturated percentages. This statement is supported by a correlation test of these factors and the heavy and saturated percentages. Therefore, an equation including these variables seems suitable for determining the heavy and saturated percentages. However, the correlation between these variables is also significant. This means that the variation in the weighted load capacity ratio can be explained by the variation in maximum load, which is actually logical because high load contributes to higher weighted load capacity ratios. It is still tried to find parameters for the equations that can determine the heavy and saturated percentages based on the weighted load capacity ratio and the maximum load on one of the approaching links by regression analysis.

The influence of the maximum load on one of the link is different per demand pattern because of the different number of links on which this maximum load occurs. Therefore, the influence of the maximum load on one of the links is multiplied with the number of links on which it occurs. This results in the next equation for the heavy and saturated percentages:

$$p_{hs,s} = \beta_{1,s} + \beta_{2,s} \times qc_w + \beta_{3,s} \times \#_{l,max} \times q_{max}$$

With:

$p_{hs,s}$  = percentage of heavy or saturated traffic state ts per speed limit s

$qc_w$  = weighted intensity capacity ratio

$\#l_{max}$  = number of links on which the maximum load occurs per demand pattern

$q_{max}$  = maximum of the loads of the approaching links

The values for the parameters  $\beta_1$ ,  $\beta_2$  and  $\beta_3$  are presented in Table 13.

**Table 13: Parameters for heavy and saturated percentage determination**

Traffic state percentage	30 km/h			50 km/h			70 km/h		
	$\beta_1$	$\beta_2$	$\beta_3$	$\beta_1$	$\beta_2$	$\beta_3$	$\beta_1$	$\beta_2$	$\beta_3$
<b>Heavy</b>	-0.230	0.344	0.050	-0.234	0.212	0.059	-0.627	0.0	0.173
<b>Saturated</b>	-4.468	3.662	0.868	-1.692	0.0	0.495	-1.398	0.0	0.451

After the determination of the heavy and saturated percentages, the junction emissions are determined for these traffic states. In this calculation the percentages are translated into the length on the approach lane on which the heavy and saturated traffic states occur. The equation for this calculation is:

$$\text{junction emission}_{hs,s} = p_{hs,s} \times 2 \times q_{tj} \times E_s(ts)$$

With:

$$p_{hs,s} =$$

percentage of heavy or saturated traffic state  $hs$  present at junction per speed limit  $s$

$q_{tj}$  = load on total junction  $tj$  (vehicles per hour)

$E_s(ts)$  = emission factor for heavy or saturated traffic state  $ts$  for speed limit  $s$  (grams per vehicle kilometre)

Finally these emission are added to the junction emission of the stop & go traffic state to form the total junction emission, the equation is:

$$\text{junction emission} = \sum_{ts} \text{junction emission}_{ts}$$

With:

junction emission = total junction emission (grams)

junction emission<sub>ts</sub> = junction emission per heavy, saturated  
or stop & go traffic state  $ts$  (grams)

## 8 Assess: Assessment II

In this chapter the same assessment as in chapter five is performed again to assess the improved static model. The results are presented per emission substance starting with CO<sub>2</sub>, then NO<sub>x</sub> and finally PM<sub>10</sub>.

For CO<sub>2</sub> the static model meet the 95% requirement for all sub sets and therewith the total sub set. This means that the improvement has the wished effect for this substance. For NO<sub>x</sub> the total percentage is slightly higher compared to the first assessment (70.83% equal). However, it still does not meet the requirement. Only for 70 kilometres per hour the model determines best junction designs compared with the dynamic model for all input criteria sets. For PM<sub>10</sub> none of the assessment remains exact equal. This means that the improvements have no effect on the calculation of the PM<sub>10</sub> values.

**Table 14: Best option with 5% bandwidth assessment for CO<sub>2</sub>.** Red colour means sub set does not satisfy the requirement, green colour means sub set satisfies the requirement. The "equal" and "not equal" represent the percentages of the number of input criteria sets for which the best option(s) are equal and not equal for the static model and the dynamic model. N is the number of input criteria sets over which the static model is assessed.

Set		Improved Static Model				Static Model			
<b>Total</b> (n = 48)	Sub set	<b>Total</b>				<b>Total</b>			
	Equal	100.00%				87.23%			
	Not equal	0.00%				12.77%			
<b>Speed Limit</b> (n = 16)	Sub set	<b>30 km/h</b>	<b>50 km/h</b>	<b>70 km/h</b>		<b>30 km/h</b>	<b>50 km/h</b>	<b>70 km/h</b>	
	Equal	100.00%	100.00%	100.00%		87.50%	86.67%	87.50%	
	Not equal	0.00%	0.00%	0.00%		12.50%	13.33%	12.50%	
<b>Total demand</b> (n = 12)	Sub set	<b>500 veh/h</b>	<b>1500 veh/h</b>	<b>2500 veh/h</b>	<b>3500 veh/h</b>	<b>500 veh/h</b>	<b>1500 veh/h</b>	<b>2500 veh/h</b>	<b>3500 veh/h</b>
	Equal	100.00%	100.00%	100.00%	100.00%	100.00%	100.00%	100.00%	45.45%
	Not equal	0.00%	0.00%	0.00%	0.00%	0.00%	0.00%	0.00%	54.55%
<b>Demand pattern</b> (n = 12)	Sub set	<b>All equal</b>	<b>Straight ahead</b>	<b>Turn</b>	<b>One direction</b>	<b>All equal</b>	<b>Straight ahead</b>	<b>Turn</b>	<b>One direction</b>
	Equal	100.00%	100.00%	100.00%	100.00%	100.00%	75.00%	75.00%	100.00%
	Not equal	0.00%	0.00%	0.00%	0.00%	0.00%	25.00%	25.00%	0.00%



Table 15: Best option with 5% bandwidth assessment for NO<sub>x</sub>. Red colour means sub set does not satisfy the requirement, green colour means sub set satisfies the requirement. The “equal” and “not equal” represent the percentages of the number of input criteria sets for which the best option(s) are equal and not equal for the static model and the dynamic model. N is the number of input criteria sets over which the static model is assessed.

Set		Improved Static Model				Static model			
<b>Total</b> (n = 48)	Sub set	<b>Total</b>				<b>Total</b>			
	Equal	72.92%				70.83%			
	Not equal	27.08%				29.17%			
<b>Speed Limit</b> (n = 16)	Sub set	<b>30 km/h</b>	<b>50 km/h</b>	<b>70 km/h</b>		<b>30 km/h</b>	<b>50 km/h</b>	<b>70 km/h</b>	
	Equal	31.25%	87.50%	100.00%		37.50%	87.50%	87.50%	
	Not equal	68.75%	12.50%	0.00%		62.50%	12.50%	12.50%	
<b>Total demand</b> (n = 12)	Sub set	<b>500 veh/h</b>	<b>1500 veh/h</b>	<b>2500 veh/h</b>	<b>3500 veh/h</b>	<b>500 veh/h</b>	<b>1500 veh/h</b>	<b>2500 veh/h</b>	<b>3500 veh/h</b>
	Equal	100.00%	75.00%	66.67%	50.00%	100.00%	83.33%	66.67%	33.33%
	Not equal	0.00%	25.00%	33.33%	50.00%	0.00%	16.67%	33.33%	66.67%
<b>Demand pattern</b> (n = 12)	Sub set	<b>All equal</b>	<b>Straight ahead</b>	<b>Turn</b>	<b>One direction</b>	<b>All equal</b>	<b>Straight ahead</b>	<b>Turn</b>	<b>One direction</b>
	Equal	83.33%	66.67%	66.67%	75.00%	83.33%	66.67%	58.33%	75.00%
	Not equal	16.67%	33.33%	33.33%	25.00%	16.67%	33.33%	41.67%	25.00%

Table 16: Best option with 5% bandwidth assessment for PM<sub>10</sub>. Red colour means sub set does not satisfy the requirement, green colour means sub set satisfies the requirement. The “equal” and “not equal” represent the percentages of the number of input criteria sets for which the best option(s) are equal and not equal for the static model and the dynamic model. N is the number of input criteria sets over which the static model is assessed.

Set		Improved Static Model				Static Model			
<b>Total</b> (n = 48)	Sub set	<b>Total</b>				<b>Total</b>			
	Equal	79.17%				79.17%			
	Not equal	20.83%				20.83%			
<b>Speed Limit</b> (n = 16)	Sub set	<b>30 km/h</b>	<b>50 km/h</b>	<b>70 km/h</b>		<b>30 km/h</b>	<b>50 km/h</b>	<b>70 km/h</b>	
	Equal	87.50%	62.50%	87.50%		87.50%	62.50%	87.50%	
	Not equal	12.50%	37.50%	12.50%		12.50%	37.50%	12.50%	
<b>Total demand</b> (n = 12)	Sub set	<b>500 veh/h</b>	<b>1500 veh/h</b>	<b>2500 veh/h</b>	<b>3500 veh/h</b>	<b>500 veh/h</b>	<b>1500 veh/h</b>	<b>2500 veh/h</b>	<b>3500 veh/h</b>
	Equal	100.00%	91.67%	83.33%	41.67%	100.00%	91.67%	83.33%	41.67%
	Not equal	0.00%	8.33%	16.67%	58.33%	0.00%	8.33%	16.67%	58.33%
<b>Demand pattern</b> (n = 12)	Sub set	<b>All equal</b>	<b>Straight ahead</b>	<b>Turn</b>	<b>One direction</b>	<b>All equal</b>	<b>Straight ahead</b>	<b>Turn</b>	<b>One direction</b>
	Equal	100.00%	58.33%	66.67%	91.67%	100.00%	58.33%	66.67%	91.67%
	Not equal	0.00%	41.67%	33.33%	8.33%	0.00%	41.67%	33.33%	8.33%

## 8.1 Wilcoxon signed rank tests

The results of the Wilcoxon signed rank tests for the ranks and for the absolute emission values are provided together and shown in Table 17 for CO<sub>2</sub>, Table 18 for NO<sub>x</sub> and

Table 19 for PM<sub>10</sub>. The tests score even worse than the tests for the initial static model. This means that for a total rank and for absolute values of all three substances that static model is not suitable.

Table 17: Wilcoxon signed rank test for CO<sub>2</sub>. Red means that the static model scores significant different than the dynamic model. Green means that both models score equal based on this test. N is the number of combinations of junction designs and input criteria sets for which the Wilcoxon signed rank test is executed.

Set		Rank/ Absolute	Improved Static Model				Static Model				
<b>Total</b> (n = 864)	Rank	Total					Total				
	Absolute	Total					Total				
<b>Speed limit</b> (n = 288)	Rank	30 km/h	50 km/h	70 km/h			30 km/h	50 km/h	70 km/h		
	Absolute	30 km/h	50 km/h	70 km/h			30 km/h	50 km/h	70 km/h		
<b>Total demand</b> (n = 216)	Rank	500 veh/h	1500 veh/h	2500 veh/h	3500 veh/h	500 veh/h	1500 veh/h	2500 veh/h	3500 veh/h		
	Absolute	500 veh/h	1500 veh/h	2500 veh/h	3500 veh/h	500 veh/h	1500 veh/h	2500 veh/h	3500 veh/h		
<b>Demand pattern</b> (n = 216)	Rank	All equal	Straigh ahead	Turn	One direction	All equal	Straigh ahead	Turn	One direction		
	Absolute	All equal	Straigh ahead	Turn	One direction	All equal	Straigh ahead	Turn	One direction		
<b>Main junction type</b> (n = 216)	Absolute	Equal junctions	Priority junctions	Signalized junctions	Roundabouts	Equal junctions	Priority junctions	Signalized junctions	Roundabouts		

Table 18: Wilcoxon signed rank test for NO<sub>x</sub>. Red means that the static model scores significant different than the dynamic model. Green means that both models score equal based on this test. N is the number of combinations of junction designs and input criteria sets for which the Wilcoxon signed rank test is executed.

Set		Rank/ Absolute	Improved Static Model				Static Model				
<b>Total</b> (n = 864)	Rank	Total					Total				
	Absolute	Total					Total				
<b>Speed limit</b> (n = 288)	Rank	30 km/h	50 km/h	70 km/h			30 km/h	50 km/h	70 km/h		
	Absolute	30 km/h	50 km/h	70 km/h			30 km/h	50 km/h	70 km/h		
<b>Total demand</b> (n = 216)	Rank	500 veh/h	1500 veh/h	2500 veh/h	3500 veh/h	500 veh/h	1500 veh/h	2500 veh/h	3500 veh/h		
	Absolute	500 veh/h	1500 veh/h	2500 veh/h	3500 veh/h	500 veh/h	1500 veh/h	2500 veh/h	3500 veh/h		
<b>Demand pattern</b> (n = 216)	Rank	All equal	Straigh ahead	Turn	One direction	All equal	Straigh ahead	Turn	One direction		
	Absolute	All equal	Straigh ahead	Turn	One direction	All equal	Straigh ahead	Turn	One direction		
<b>Main junction type</b> (n = 216)	Absolute	Equal junctions	Priority junctions	Signalized junctions	Roundabouts	Equal junctions	Priority junctions	Signalized junctions	Roundabouts		

Table 19: Wilcoxon signed rank test for PM<sub>10</sub>. Red means that the static model scores significant different than the dynamic model. Green means that both models score equal based on this test. N is the number of combinations of junction designs and input criteria sets for which the Wilcoxon signed rank test is executed.

Set	Rank/ Absolute	Improved Static Model				Static Model			
		Total				Total			
<b>Total</b> (n = 864)	Rank								
	Absolute	Total				Total			
<b>Speed limit</b> (n = 288)	Rank	30 km/h	50 km/h	70 km/h		30 km/h	50 km/h	70 km/h	
	Absolute	30 km/h	50 km/h	70 km/h		30 km/h	50 km/h	70 km/h	
<b>Total demand</b> (n = 216)	Rank	500 veh/h	1500 veh/h	2500 veh/h	3500 veh/h	500 veh/h	1500 veh/h	2500 veh/h	3500 veh/h
	Absolute	500 veh/h	1500 veh/h	2500 veh/h	3500 veh/h	500 veh/h	1500 veh/h	2500 veh/h	3500 veh/h
<b>Demand pattern</b> (n = 216)	Rank	All equal	Straigh ahead	Turn	One direction	All equal	Straigh ahead	Turn	One direction
	Absolute	All equal	Straigh ahead	Turn	One direction	All equal	Straigh ahead	Turn	One direction
<b>Main junction type</b> (n = 216)	Absolute	Equal junctions	Priority junctions	Signalized junctions	Roundabouts	Equal junctions	Priority junctions	Signalized junctions	Roundabouts

## 8.2 Conclusion

The assessment shows that:

- The static model does meet the 95% requirement for CO<sub>2</sub>. This means that the static model is suitable for determining the best option with 5% bandwidth for this substance.
- The static model does not meet the requirement for NO<sub>x</sub> and PM<sub>10</sub>. Which means that the model have to be improved for determining the best option with 5% bandwidth for these substances.
- The static model does meet the requirement for all substances for 500 vehicles per hour. Which is already explained in assessment I.
- The static model statistically models a different total rank than the dynamic model. Again only for some sub sets the rank is not significantly different. The same counts for the absolute emission values for all three substances.

Summarising is stated that the static model can be used for determining the best option with 5% bandwidth for CO<sub>2</sub> only. However, for absolute values the model is not suitable for this substance. For the other two substances the model is not suitable for determining best option with 5% bandwidth and absolute emission values.

## 9 Conclusions

In this chapter the main research question is answered by drawing conclusions. Conclusions are drawn and discussed for the static model (section 9.1.1) and the results of the model (section 9.1.2). After that the implications of this research and directions for future research are provided.

### 9.1 Conclusion

The objective of this research was to develop a static macroscopic junction emission model. This model should produce results that can be used to compare different junction designs on policy relevant emission substances. In order to achieve the objective the next main research question was formulated:

*In what way can emission exhaust of traffic on junctions in urban networks be modelled using static macroscopic emission modelling to compare different junction designs on policy relevant emission substances?*

To answer the main research question an iterative process is conducted to include all three criteria formulated for the model in the design process. In this conclusion two elements are distinguished. The actual static macroscopic junction emission model and the assessment of this model.

#### 9.1.1 Static macroscopic junction emission model

The static macroscopic junction emission model is executed in four steps:

1. Determine the queue length per turning direction
2. Determine the stop & go length per turning direction
3. Determine the emissions per turning direction and total junction
4. Add emissions caused by heavy and saturated traffic state

The queue length calculation is based on the average delay per vehicle per turn. The max queue length per turn is the load on that turn multiplied with the vehicle length. The queue length is determined by the equation:

$$Q_t = d_t \times q_t \times l_{veh}$$

With:

$Q_t$  = queue length per turn  $t$  (kilometres)

$d_t$  = average delay per vehicle on turn  $t$  (hours)

$q_t$  = load on turn  $t$  (vehicles per hour)

$l_{veh}$  = vehicle length (kilometres)

The stop & go length is introduced to determine the length of the link where vehicles pass the junction in a stop & go traffic state. The stop & go length is determined by including reasoning for different approach lane configurations and including the blocking effect. The blocking effect occurs when the queue on one or more approach lanes exceed the approach lane length. In that case all stop & go lengths for the concerning link are set to the approach lane length increased with the sum of the exceeding parts of the exceeding queue lengths.

The stop & go length is used for the emission calculation. For the stop & go length, vehicles pass the approaching link in the stop & go traffic state. The emission values of the junctions based on the stop & go lengths per turn is calculated with:

$$junction\ emission_{sg} = \sum_t SG_t \times E_s(sg) \times q_t$$

With:

$SG_t$  = length for which the stop & go traffic state is determined for turn  $t$  (kilometres)

$E_s(sg)$  = stop & go emission factor for speed limit  $s$  (grams per vehicle kilometre)

$q_t$  = load on turn  $t$  (vehicles per hour)

In the last step, the emissions caused by the heavy and saturated traffic states are added to the stop & go junction emission. A percentage of the 2 kilometre link is assigned to both traffic states. These percentages are calculated using the weighted load capacity ratio and the maximum of the approaching link loads. The equation for determining the percentages is:

$$p_{hs,s} = \beta_{1,s} + \beta_{2,s} \times qc_w + \beta_{3,s} \times \#_{l,max} \times q_{max}$$

With:

$p_{hs,s}$  = percentage of heavy or saturated traffic state  $hs$  per speed limit  $s$

$qc_w$  = weighted intensity capacity ratio

$\#_{l,max}$  = number of links on which the maximum load occurs per demand pattern

$q_{max}$  = maximum of the loads of the approaching links

The values for the parameters  $\beta_1$ ,  $\beta_2$  and  $\beta_3$  are presented in Table 13.

**Table 20: Parameters for heavy and saturated percentage determination**

Traffic state percentage	30 km/h			50 km/h			70 km/h		
	$\beta_1$	$\beta_2$	$\beta_3$	$\beta_1$	$\beta_2$	$\beta_3$	$\beta_1$	$\beta_2$	$\beta_3$
<b>Heavy</b>	-0.230	0.344	0.050	-0.234	0.212	0.059	-0.627	0.0	0.173
<b>Saturated</b>	-4.468	3.662	0.868	-1.692	0.0	0.495	-1.398	0.0	0.451

After the determination of the heavy and saturated percentages, the junction emissions are determined for these traffic states with the equation:

After the determination of the heavy and saturated percentages, the junction emissions are determined for these traffic states. In this calculation the percentages are translated into the length on the approach lane on which the heavy and saturated traffic states occur. The equation for this calculation is:

$$junction\ emission_{hs,s} = p_{hs,s} \times 2 \times q_{tj} \times E_s(ts)$$

With:

$p_{hs,s} =$

*percentage of heavy or saturated traffic state hs present at junction per speed limit s*

$q_{tj} =$  *load on total junction tj (vehicles per hour)*

$E_s(ts) =$  *emission factor for heavy or saturated traffic state ts for speed limit s (grams per vehicle kilometre)*

Finally these emission are added to the junction emission of the stop & go traffic state to form the total junction emission, the equation is:

$$\text{junction emission} = \sum_{ts} \text{junction emission}_{ts}$$

With:

$\text{junction emission} =$  *total junction emission (grams)*

$\text{junction emission}_{ts} =$  *junction emission per heavy, saturated*

*or stop & go traffic state ts (grams)*

### **Discussion**

The queue length calculation of the static model can be a point of discussion because a pseudo situation is used for determining the average queue length. Furthermore, queuing vehicles actually have a steady state, while a stop & go state has not. However, the analysis of the percentage stop & go traffic state on the junction showed that the queue length translated into the stop & go length produces relative similar results as the dynamic model.

Including the heavy and saturated traffic states could be performed more accurate for the modelling framework used in this research. In that case average percentages for the heavy and saturated traffic states were determined per speed limit and total demand. However, the results should become not useful for generic use and the static model not extensible. Therefore, the analysis for these traffic states focussed on variables that can be generated for other junction designs, junction demand criteria and network criteria too. The parameters  $\beta_1$ ,  $\beta_2$  and  $\beta_3$  are actually determined based on the used modelling framework.

The process that led to the static model has limitations. First subject in this discussion is the modelling framework concerning the junction design criteria, junction demand criteria and network criteria. Despite the fact that the elements in the modelling framework are chosen to vary over the wide range of reality alike possibilities it remains a small representation of the these possibilities. The narrowed scope elements also contribute to this small representation of reality. This makes that the model should be carefully used for other junction design criteria, junction demand criteria and network criteria than used in this model. The reasoning behind the model can be extended to elements of junctions that are not in the modelling framework. However, the parameters should be used very carefully.

Furthermore, the dynamic macroscopic junction emission model is an adaptation to the dynamic emission model for the use on links of Wismans (2012). However, this adaptation is carefully made

the assumptions forming the base for the link emission model can have a negative influence on the reliability of the emission results on junctions.

Third point is the method for reasoning that is used to design the static macroscopic junction emission model. This reasoning is: the queue length estimation based on the average delay per vehicle per turn, the stop & go length determination and last including the heavy and saturated traffic states into the model. This reasoning is carefully thought of but are not supported by literature.

**9.1.2 Assessment**

The final assessment is performed by determining the best junction design per input criteria set + 5% bandwidth for the static model and comparing it to the dynamic model. If one or more best junction designs are determined by both models are equal the static model produces satisfying results for that input criteria set. This is performed for all input criteria sets. Finally, the percentage of equal results in the whole dataset or sub sets are determined. When the percentage equals is lower than 95% the assessment is that the static macroscopic junction emission model produces results that are not useful to compare different junction designs for the decision support tool. Furthermore, the total ranks and absolute values are assessed by a Wilcoxon signed rank test.

Summary of the 95% requirement criteria results is shown in Table 21. It is shown that the model produces useful results for CO<sub>2</sub> because the total and all sub sets meet the 95% requirement. For NO<sub>x</sub> and PM<sub>10</sub> the requirement is only met for a small number of sub sets. Which means that the model should be improved to produces useful results for the other sub sets for these substances. In addition the Wilcoxon signed rank tests do not score equal for the static model and dynamic model for most sub sets of all three substances. Herewith is concluded that the static macroscopic junction emission model is only suitable for determining best junction design with 5% bandwidth for CO<sub>2</sub>. For the other substances and determining absolute emission values the static models needs to be improved.

**Table 21: Best option with 5% bandwidth assessment for CO<sub>2</sub>, NO<sub>x</sub> and PM<sub>10</sub>. Red colour means sub set does not satisfy the 95% requirement, green colour means sub set satisfies the 95% requirement. N is the number of input criteria sets over which the static model is assessed.**

Set					
<b>Total</b> (n = 48)	CO <sub>2</sub>	Total			
	NO <sub>x</sub>	Total			
	PM <sub>10</sub>	Total			
<b>Speed Limit</b> (n = 16)	CO <sub>2</sub>	30 km/h	50 km/h	70 km/h	
	NO <sub>x</sub>	30 km/h	50 km/h	70 km/h	
	PM <sub>10</sub>	30 km/h	50 km/h	70 km/h	
<b>Total demand</b> (n = 12)	CO <sub>2</sub>	500 veh/h	1500 veh/h	2500 veh/h	3500 veh/h
	NO <sub>x</sub>	500 veh/h	1500 veh/h	2500 veh/h	3500 veh/h
	PM <sub>10</sub>	500 veh/h	1500 veh/h	2500 veh/h	3500 veh/h
<b>Demand pattern</b> (n = 12)	CO <sub>2</sub>	All equal	Straight ahead	Turn	One direction
	NO <sub>x</sub>	All equal	Straight ahead	Turn	One direction
	PM <sub>10</sub>	All equal	Straight ahead	Turn	One direction

## ***Discussion***

Remarkable point is that the model produces satisfying results for all three substances for a total demand of 500 vehicles per hour. This is caused by the fact that the dynamic model determines no differences between junction designs. In these cases all traffic passes the junction in a free flow traffic state. This results in all junction designs are determined as best option. In contrast, the static model does produce emission values that are different per junction design. This is caused by (slight) differences in the average delay per vehicle per turn. This results in all best junction designs determined by the static model are equal to one of the junction designs determined by the dynamic model. This can be interpreted as the static model produces useful results for all three substances for the sub set 500 vehicles per hour. However, it can also be interpreted as pseudo-accuracy of the static model. Using static macroscopic traffic performances to calculate emissions on junctions results in emission values that should be interpreted carefully and some margins have to be taken in mind. Therefore, it cannot be concluded that the model is suitable for small junction demand criteria. In practise, it will also proved that emission values of junction designs for such small junction demand criteria do not reach emission standards. Therefore, the differences in emission values between junction designs have little relevance in the decision process.

## **9.2 Implications and future research directions**

This research led to a static macroscopic junction emission model. With this model junction designs can be compared for the emissions  $\text{CO}_2$ ,  $\text{NO}_x$  and  $\text{PM}_{10}$ . As already stated in the motive it is difficult to determine emissions, especially on junctions, because variations in speed have a high contribution to the emission values. Therefore, this model should be used for determining the best junction design(s) with a bandwidth. Herewith, all junction designs within a range of 5% are determined as best junction design. The percentage of 5% is used in this research to assess the model but this can be changed according the wishes of the user. The model should not be used to determine absolute emission values. For that purpose the model has too many uncertainties and assumptions. And the assessment shows significant differences between the static model and dynamic model for absolute emission values for all substances. Furthermore this model is determined for a small part of reality alike possibilities, as already stated in the discussion of the model. In relation to the research of Bezembinder for which this research is conducted, the model can be improved and extended. Especially, because the junction emission model is intended to use for network calculation instead of individual junction designs. Therefore, it is tried to develop a model which can be extended to network level.

Analysis of the traffic performances showed that the dynamic model does have different traffic performances per speed limit. Despite the fact that it is tried to include these effects by different parameters for the determination of the heavy and saturated emission values the effect of the speed limits on the stop & go is not incorporated. Therefore, the emission calculation can be improved by including the effects of different speed limits in the calculation of the stop & go length. Because the parameters for the determination of the heavy and saturated traffic states are already estimated per speed limit, these effects only have to be included for the stop & go length.

Last suggestion is to determine the heavy and saturated traffic states per approaching link instead of the total junction. With this improvement the heavy and saturated are better connected to the network performance. This measure causes that the weighted load capacity ratio cannot be used



because this is a measure for the total junction. Therefore, the load capacity per approaching link is determinative for the heavy and saturated impact on the total emission value of that link.

With the current insights about emission modelling in relation with the research of Bezembinder it is suggested that first all wished elements influencing junction traffic performances are included in the junction modelling. And after that, the parameters for the heavy and saturated traffic states are estimated. The directions for improving and extending the model are:

- Elements that are not included but can have an influence on the emission values are: variations in signalling scheme, variations in approach lane length, variations in approach lane configuration, and other junction types (e.g. turbo roundabout). Summarizing, an extension junction design criteria. For variations in approach lane configuration, reasoning for determining the stop and go length need to be adjusted. Furthermore, the parameters for determining the heavy and saturated percentages need to be determined again.
- Other extensions can be made for the junction demand criteria. Other vehicle categories can be investigated individually but also in combination with other vehicle categories. For each vehicle category different emission factors need to be used. Furthermore, the junction performance measures change due to other vehicle characteristics and interaction between vehicle categories. In addition, slow traffic and public transport can be included in the model. Slow traffic only influences the junction performance measure but do not generate emissions themselves. However, public transport influences the junction performance measures and generate emissions themselves.
- Last element of the modelling framework are the network criteria. These can be extended by other speed limits, more lanes on the approaching link and including the exit link in the junction emission calculation. More lanes on the approaching link causing the reasoning for the approach lane configuration change. The blocking effect is different, the effect of traffic changing lanes should be investigated. Although it is assumed that the exit lanes do have a small influence on the junction emission, they do have some influence. Especially when the number of exit lanes differs for two junction designs.
- The modelling framework in this research was chosen to vary over a range of reality alike possibilities. However, for the analysis it is suggested that future research uses elements in the modelling framework that differ over a range per variable for a number of variables. For example, in this research the demand patterns are four totally different patterns. Instead of these patterns, a range of "percentage of left turning traffic" can be used. This narrows the scope of but makes it easier to analyse the results and identify improvements to the model.

## 10 Literature

- Augustijn, Denie. (2006). *Civieltechnische Milieukunde*: Universiteit Twente.
- Baarda, B., Dijkum, C. van, & Goede, M. de. (2014). *Basisboek Statistiek met SPSS*. Groningen/Houten: Noordhoff Uitgevers.
- Baarda, D.B., & Goede, M.P.M. de. (1992). *Basisboek methoden en technieken: praktische handleiding voor het opzetten en uitvoeren van onderzoek*. Leiden: Stenfert Kroese uitgevers.
- Bezembinder, Erwin. (2013). Multi-objective junction design rules for urban traffic networks. Zwolle.
- CBS, & PBL. (2013). Aantal motorvoertuigen, 1990-2013. Retrieved December 2, 2013, from <http://www.compendiumvoordeleefomgeving.nl/indicatoren/nl0026-Aantal-motorvoertuigen.html?i=15-103>
- CBS, PBL, & UR, Wageningen. (2010). Milieudruk doelgroep Verkeer en vervoer: een overzicht. Retrieved 13 November, 2013, from <http://www.compendiumvoordeleefomgeving.nl/indicatoren/nl0126-Inleiding-milieudruk-verkeer-en-vervoer.html?i=15-103>
- CBS, PBL, & UR, Wageningen. (2011). Klimaatverandering: beleid ter vermindering van broeikasgasemissies. April 7th, 2008. Retrieved January 24, 2014, from <http://www.compendiumvoordeleefomgeving.nl/indicatoren/nl0164-Klimaatbeleid.html?i=9-53>
- CBS, PBL, & UR, Wageningen. (2013a). Nationale luchtkwaliteit: beleid. Retrieved January 29, 2014, from <http://www.compendiumvoordeleefomgeving.nl/indicatoren/nl0230-Nationale-luchtkwaliteit%3A-beleid.html?i=14-65>
- CBS, PBL, & UR, Wageningen. (2013b). Nationale luchtkwaliteit: Overzicht normen. Retrieved 13 November, 2013, from <http://www.compendiumvoordeleefomgeving.nl/indicatoren/nl0237-Nationale-luchtkwaliteit%3A-overzicht-normen.html?i=14-65>
- CBS, PBL, & UR, Wageningen. (2013c). Nationale luchtkwaliteit: overzicht normen. Retrieved 24 July, 2014, from <http://www.compendiumvoordeleefomgeving.nl/indicatoren/nl0237-Nationale-luchtkwaliteit%3A-overzicht-normen.html?i=14-65>
- CROW. (2010). *Kruispunten en luchtkwaliteit: Een vergelijking tussen rotondes, verkeerslichten en groene golven*. Ede: CROW.
- CROW. (2012). *ASVV 2012 - Aanbevelingen voor verkeersvoorzieningen binnen de bebouwde kom*. Ede: CROW.
- Fang, F.C., & Elefteriadou, L. (2008). Capability-enhanced microscopic simulation with real-time traffic signal control. *IEEE Transactions on Intelligent Transportation Systems*, 9(4), 625-632.
- Faris, W.F., Rakha, H.A., Kafafy, R.I., Idres, M., & Elmoselhy, S. (2011). Vehicle fuel consumption and emission modelling: an in-depth literature review. *Int. J. Vehicle Systems Modelling and Testing*, 6, 318-395.
- Hickman, A. J. (1999). Methodology for calculating transport emissions and energy consumption: Transportation Research Laboratory.
- Hourdakis, John, Michalopoulos, Panos G., & Kottommannil, Jiji. (2003). *A practical procedure for calibrating microscopic traffic simulation models*. Paper presented at the Transportation Research Board 2003 Annual Meeting, Washington, D.C.
- Marsden, G.R., Bell, M.C., & Reynolds, S.A. (2001). Towards a real-time microscopic emissions model. *Transportation Research Part D: Transport & Environment*, 6(1), 37-60.
- MilieuCentraal.). Broeikaseffect. Retrieved December 2, 2013, from <http://www.milieucentraal.nl/thema's/thema-1/klimaat-en-milieu Problemen/klimaatverandering/broeikaseffect/>
- Pandian, Suresh, Gokhale, Sharad, & Ghoshal, Alope Kumar. (2009). Evaluating effects of traffic and vehicle characteristics on vehicular emissions near traffic intersections. *Transportation Research Part D*, 14, 180-196.
- Rakha, Hesham, Aerde, Michel van, & Trani, Antonio A. (2000). Requirements for evaluating traffic signal control impacts on energy and emissions based on instantaneous speed and

- acceleration measurements. *Transportation Research Record: Journal of the Transportation Research Board*(Volume 1738 / 2000 Energy, Air Quality, and Fuels 2000), 56-67.
- Smit, Robin. (2006). An examination of congestion in road traffic emission models and their application to urban road networks (F. o. E. Sciences, Trans.): School of Environmental Planning.
- Wismans, Luc. (2012). *Towards sustainable dynamic traffic management*. (Doctor), University of Twente.
- Yue, Huanyu. (2008). Mesoscopic fuel consumption and emission modeling [Doctor of Philosophy dissertation]: Virginia Polytechnic Institute and State University.

## Appendices

### A Appendix: OmniTRANS delay calculation

The junction module calculates the delay in two steps. First, the capacity is calculated and using this capacity the delay is calculated. The static delay includes three components: the uniform delay, the incremental delay and the geometric delay. The dynamic delay only includes the incremental delay. The others are already taken into account in the network loading part.

#### A.1 Delay calculation for an equal junction

The calculation of the capacity is divided into two parts. The first part calculates the capacity per lane group. In the second part, the V/C-ratio of each lane group which has to give way is taken into account.

##### A.1.1 Capacity calculation – part 1

The capacity is calculated using the following equation:

$$Q_{b,lg} = \max\left(\frac{1}{\gamma} \delta \left(s_{lg} - 0.99(\alpha l_{AC} + \beta l_c)\right), Q_{min}\right)$$

$$l_{AC} = \sum_{lg \in AC_{lg}} l_{lg}$$

$$l_c = \sum_{lg \in C_{lg}} l_{lg}$$

With:

$Q_{b,lg}$  = base capacity of lane group  $lg$

$Q_{min}$  = minimal capacity

$s_{lg}$  = saturation flow of lane group  $lg$

$l_{AC}$  = load of the apparent – conflict movements

$l_c$  = load of the conflict movements

$l_{lg}$  = load of lane group

$AC_{lg}$  = set of lane groups that have an apparent – conflict with lane group  $lg$

$C_{lg}$  = set of lane groups that have a conflict with lane group  $lg$

The values of the parameters  $\alpha$ ,  $\beta$ ,  $\gamma$  and  $\delta$  are calculated as follows:

$$\alpha = \alpha_b \left(1 + \frac{1}{3} - \frac{2}{3} \sqrt{\frac{l_{AC} - l_c}{s_b l_{AC} + l_c}}\right)$$

$$\alpha_b = 0.5$$

$$\beta = \begin{cases} 1 \rightarrow 1 \text{ exit lane on crossing road} \\ 0.7 \rightarrow 2 \text{ or more exit lanes on crossing road} \end{cases}$$

$$\gamma = \begin{cases} 1 \rightarrow 1 \text{ entry lane} \\ 0.6 \rightarrow 2 \text{ entry lanes} \\ 0.4 \rightarrow 3 \text{ or more entry lanes} \end{cases}$$

$$\delta = \begin{cases} 1 \rightarrow \text{right turn} \\ 0.8 \rightarrow \text{through movement} \\ 0.6 \rightarrow \text{left turn} \end{cases}$$

### A.1.2 Capacity calculation - part 2

Based on the calculated capacities, the V/C-ratios can be calculated. If one of these ratios exceeds 1.0 (oversaturated situation), all capacities will be calculated again (part 1), where the loads of the lane groups with oversaturated situation will be adjusted:

$$Q_{lg} = \begin{cases} Q_{b,lg} \rightarrow \frac{l_{lg}}{Q_{b,lg}} \leq 1 \\ Q_{b,new} \rightarrow \frac{l_{lg}}{Q_{b,lg}} > 1 \end{cases}$$

With

$Q_{lg}$  = capacity of lane group  $lg$

$Q_{b,lg}$  = base capacity of lane group  $lg$

$Q_{b,new}$  = new calculation of  $Q_{b,lg}$  with  $l_{lg,new}$

$$l_{lg,new} = \begin{cases} \frac{s_{lg}}{\gamma} \rightarrow l_{lg} > \frac{s_{lg}}{\gamma} \\ \frac{19}{20} l_{lg} \rightarrow Q_{b,lg} < l_{lg} \leq \frac{s_{lg}}{\gamma} \end{cases}$$

After this procedure, the lane group capacity will be used for calculate the lane capacity:

$$Q_l = \frac{1}{\sum_{i \in lg} \left[ \frac{l_i}{\sum_{i \in lg} l_i Q_i} \right]}$$

With:

$Q_l$  = capacity of lane  $l$

$Q_i$  = capacity of lane group  $i$

$l_i$  = load of lane group  $i$

$l_j$  = load of lane group  $j$

### A.1.3 Delay calculation

The calculation of the average delay uses two parameters, these are load and capacity. The calculation of the delay is given in the next equation:

$$D_l = \min (d_{1,l} + d_{2,l} + d_{3,l}, d_{max,l})$$

With:

$D_l =$  Average delay on lane  $l$

$d_{1,l} =$  Uniform delay on lane  $l$

$d_{2,l} =$  Incremental delay on lane  $l$

$d_{3,l} =$  Geometric delay on lane  $l$

$d_{max,l} =$  Maximum delay on lane  $l$

The uniform delay is calculated in the way of:

$$d_{1,l} = \frac{3600}{Ql}$$

With:

$Ql =$  capacity of lane  $l$

The incremental delay is calculated in the way of:

$$d_{2,l} = \begin{cases} 900T(Y_l)^N \left[ (Y_l - 1) + \sqrt{(Y_l - 1)^2 + \frac{MK(Y_l - Y_0)}{Q_l T}} \right] \rightarrow Y_l > Y_0 \\ 0 \rightarrow Y_l \leq Y_0 \end{cases}$$

With:

$T =$  duration of the project

$$Y_l = \frac{l_l}{Q_l}$$

$$Y_0 = 0.5$$

The calculation of the geometric delay is calculated as follows:

$$d_{3,l} = \begin{cases} 1 \rightarrow l > 0 \\ 0 \rightarrow l = 0 \end{cases}$$

As mentioned in the introduction, the delay in a dynamic situation only includes the incremental delay. In that case the uniform and geometric delays are set to 0.

## A.2 Delay calculation for a priority junction

The calculation of the V/C-ratio for a priority junction is almost the same as the calculation for an equal junction. The difference appears in a factor for extra lanes that should be crossed ( $c_{c1}$ ) and a factor for the central reservation where a vehicle could wait to go further ( $c_{c2}$ ).

### A.2.1 Capacity calculation - part 1

The capacity is calculated using the following equation:

$$Q_{b,lg} = \max \left( \frac{1}{\gamma} \delta \left( S_{lg} - 0.99(\alpha l_{AC} + \beta l_c) \right) + c_{c1} + c_{c2}, Q_{min} \right)$$

$$l_{AC} = \sum_{lg \in AC_{lg}} l_{lg}$$

$$l_c = \sum_{lg \in C_{lg}} l_{lg}$$

Whith:

$Q_{b,lg}$  = base capacity of lange group  $lg$

$Q_{min}$  = minimal capacity

$s_{lg}$  = saturation flow of lane group  $lg$

$l_{AC}$  = load of the apparent – conflictt movements

$l_c$  = load of the conflict movements

$l_{lg}$  = load of lane group

$AC_{lg}$  = set of lane groups that have an apparent – conflict with lane group  $lg$

$C_{lg}$  = set of lane groups that have a conflict with lane group  $lg$

The values of the parameters  $\alpha$ ,  $\beta$ ,  $\gamma$  and  $\delta$  are calculated as follows:

$$\alpha = \alpha_b \left( 1 + \frac{1}{3} - \frac{2}{3} \sqrt{\frac{l_{AC}}{s_b} \frac{l_{AC}}{l_{AC} + l_c}} \right)$$

$$\alpha_b = 0.5$$

$$\beta = \begin{cases} 1 & \rightarrow 1 \text{ exit lane on crossing road} \\ 0.7 & \rightarrow 2 \text{ or more exit lanes on crossing road} \end{cases}$$

$$\gamma = \begin{cases} 1 & \rightarrow 1 \text{ entry lane} \\ 0.6 & \rightarrow 2 \text{ entry lanes} \\ 0.4 & \rightarrow 3 \text{ or more entry lanes} \end{cases}$$

$$\delta = \begin{cases} 1 & \rightarrow \text{major road} \\ 0.8 & \rightarrow \text{through } \frac{\text{movement}}{\text{left}} \text{ turnon minor road} \\ 0.6 & \rightarrow \text{right turn on minor road} \end{cases}$$

### ***Influence of crossing multiple conflicting lanes ( $c_{c1}$ )***

The base capacity will be lowered with  $50/\gamma$ , who has to give way and has to cross at least two lanes of the concerning exit.

### ***Influence of the width on the central reservation ( $c_{c2}$ )***

When at least one vehicle can be placed on the crossing area, i.e. the width is larger than the length of one vehicle, the base capacity of several lane groups (who has to give way) will be heightened with  $100/\gamma$ .

The values of these capacity corrections are calculated as follows:

$$c_{c1} = \begin{cases} \text{straight priority} \rightarrow \begin{cases} \lg 5,6 \text{ and exit lane} > 1 \text{ on branch 1} \rightarrow \frac{-50}{\gamma} \\ \lg 11,12 \text{ and exit lane} > 1 \text{ on branch 3} \rightarrow \frac{-50}{\gamma} \\ \text{else } 0 \end{cases} \\ \text{turn priority} \rightarrow \begin{cases} \lg 8,12 \text{ and exit lane} > 1 \text{ on branch 2} \rightarrow \frac{-50}{\gamma} \\ \text{else } 0 \end{cases} \end{cases}$$

$$c_{c2} = \begin{cases} \text{straight priority} \rightarrow \begin{cases} \lg 5,6 \text{ and } w_m \geq v_q \text{ on branch 1} \rightarrow \frac{100}{\gamma} \\ \lg 11,12 \text{ and } w_m \geq v_q \text{ on branch 3} \rightarrow \frac{100}{\gamma} \\ \text{else } 0 \end{cases} \\ \text{turn priority} \rightarrow \begin{cases} \lg 8,12 \text{ and } w_m \geq v_q \text{ on branch 2} \rightarrow \frac{100}{\gamma} \\ \text{else } 0 \end{cases} \end{cases}$$

With:

$w_m$  = width of the median of the junction

$v_q$  = space needed for a vehicle to queue

### A.2.2 Capacity calculation - part 2

Based on the calculated capacities, the V/C-ratios can be calculated. If one of these ratios exceeds 1.0 (oversaturated situation), all capacities will be calculated again (part 1), where the loads of the lane groups with oversaturated situation will be adjusted:

$$Q_{b,lg} = \begin{cases} Q_{b,lg} \rightarrow \frac{l_{lg}}{Q_{b,lg}} \leq 1 \\ Q_{b,new} \rightarrow \frac{l_{lg}}{Q_{b,lg}} > 1 \end{cases}$$

With

$Q_{lg}$  = capacity of lane group  $lg$

$Q_{b,lg}$  = base capacity of lane group  $lg$

$Q_{b,new}$  = new calculation of  $Q_{b,lg}$  with  $l_{lg,new}$

$$l_{lg,new} = \begin{cases} \frac{s_{lg}}{\gamma} \rightarrow l_{lg} > \frac{s_{lg}}{\gamma} \\ \frac{19}{20} l_{lg} \rightarrow Q_{b,lg} < l_{lg} \leq \frac{s_{lg}}{\gamma} \end{cases}$$

After this procedure, the lane group capacity will be used for calculate the lane capacity:

$$Q_l = \frac{1}{\sum_{i \in lg} \left[ \frac{l_i - 1}{\sum_{i \in lg} l_i q_i} \right]}$$

With:

$Q_l$  = capacity of lane  $l$



$Q_i = \text{capacity of lane group } i$

$l_i = \text{load of lane group } i$

$l_j = \text{load of lane group } j$ .

### A.2.3 Delay calculation

The calculation of the average delay uses two parameters, these are load and capacity. The calculation of the delay is given in the next equation:

$$D_l = \min (d_{1,l} + d_{2,l} + d_{3,l}, d_{max,l})$$

With:

$D_l = \text{Average delay on lane } l$

$d_{1,l} = \text{Uniform delay on lane } l$

$d_{2,l} = \text{Incremental delay on lane } l$

$d_{3,l} = \text{Geometric delay on lane } l$

$d_{max,l} = \text{Maximum delay on lane } l$

The uniform delay is calculated in the way of:

$$d_{1,l} = \begin{cases} \text{straight priority} \rightarrow \begin{cases} \lg 4, 5, 6, 10, 11 \text{ or } 12 \rightarrow \frac{3600}{Ql} \\ \text{else} \rightarrow 0 \end{cases} \\ \text{turn priority} \rightarrow \begin{cases} \lg 7, 8, 9, 10, 11 \text{ or } 12 \rightarrow \frac{3600}{Ql} \\ \text{else} \rightarrow 0 \end{cases} \end{cases}$$

With:

$Ql = \text{capacity of lane } l$

The incremental delay is calculated in the way of:

$$d_{2,l} = \begin{cases} 900T(Y_l)^N \left[ (Y_l - 1) + \sqrt{(Y_l - 1)^2 + \frac{MK(Y_l - Y_0)}{Q_l T}} \right] \rightarrow Y_l > Y_0 \\ 0 \rightarrow Y_l \leq Y_0 \end{cases}$$

With:

$T = \text{duration of the project}$

$$Y_l = \frac{l_i}{Q_i}$$

$$Y_0 = \begin{cases} \text{straight priority} \rightarrow \begin{cases} \lg 4, 5, 6, 10, 11 \text{ or } 12 \rightarrow 0.5 \\ \text{else} \rightarrow 1 \end{cases} \\ \text{turn priority} \rightarrow \begin{cases} \lg 4, 5, 6, 10, 11 \text{ or } 12 \rightarrow 0.5 \\ \text{else} \rightarrow 1 \end{cases} \end{cases}$$

The calculation of the geometric delay is calculated as follows:

$$d_{3,l} = \begin{cases} \text{major road with only through movement} \rightarrow 0 \\ \text{major road with left or right movement} \rightarrow 1 \\ \text{else} \rightarrow dp(1 - fth_l) + fth_l \end{cases}$$

With:

$$fth_l = \frac{l_{th}}{l_{lt} + l_{th} + l_{rt}}$$

$l_l$  = load on lane  $l$

$l_{lt}$  = load of left turn movements

$l_{th}$  = load of through movements

$l_{rt}$  = load of right turn movements

As mentioned in the introduction, the delay in a dynamic situation only includes the incremental delay. In that case the uniform and geometric delays are set to 0.

### A.3 Delay calculation for a signalized junction

The calculation of the capacity is done by lane group. In the case of an signalized junction, the software creates signal groups based on the layout of the junction. This means that for each branch one to three signal groups are defined, depending the definition of the lanes on this branch. For each signal group, the movements (left, straight or right) are determined. This means that the definition of lane groups is equal to signal groups in case of a signalized junction.

Slow traffic and bus lanes are taken into account when calculating the cycle time. However, in a pragmatic way.

Each turn has a base capacity, which is equal to the saturation flow:

$$Q_{b,t} = s_t$$

With

$Q_{b,t}$  = base capacity of turn  $t$

$s_t$  = saturation flow of turn  $t$

Next, the base capacity per lane group can be calculated:

$$Q_{b,l} = \frac{\sum_{turn\ t \in l} Q_{b,t}}{nr_{t,l}}$$

$$Q_{b,lg} = \sum_{l \in lanes} Q_{b,l}$$

With:

$Q_{b,l}$  = base capacity of lane  $l$

$Q_{b,lg}$  = base capacity of lane group  $lg$

$nr$  = number of turns on lane  $l$

After the calculation of the base capacity, the loads are distributed of the lanes in such a way that every lane has about the same load-capacity ratio in the same signal groups:

$$\sum_{turn\ t \in lane\ l} \frac{l_{t \in l}}{Q_{b,t}} \approx \sum_{turn\ t \in lane\ j} \frac{l_{t \in j}}{Q_{b,t}}$$

With:

$l_{t \in l}$  = load of turn  $t$  on lane  $l$

The loads of the lane groups are simply the sum of the loads of the lanes.

Based on the conflict matrix, the normative maximum conflict group can be created.

The maximum conflict groups are essential for the planning of the green times of a traffic light. The groups consist of lane groups which are in conflict with all the other lane groups in the group. The creation of these maximum conflict groups happens in the following manner: per branch the lane groups are examined and compared with lane groups of other branches, when they are all in conflict, these lane groups together are a maximum conflict group. The normative maximum conflict group is the group with the highest signal cycle time. For the comparison of the cycle times, these are calculated in the following manner. First the base cycle time is calculated. This calculation uses the variables total loss time and the load/capacity ratio:

$$t_{tl} = t_{cl} + \sum_{p \in phases} (t_y - t_{end} + t_{start})$$

$$Y_t = \sum_{p \in phases} (l \in lanes\ of\ p \left( \frac{l_l}{Q_{b,l}} \right))$$

With:

$Y_t$  = total load/capacity ratio

$t_{tl}$  = total loss time

$t_{cl}$  = total clearance time (sum of the inter – green times per lane group)

After the computation of the maximum-cycle time, the green-times of the lane groups are calculated in the following way:

$$gt_p = \min (gt_{max}, \max \left( gt_{min}, \frac{Y_p}{Y_t} (Ct_{max} - t_{tl}) \right))$$

With:

$gt_p$  = green – time of phase  $p$

$Y_p = \text{load/capacity ratio of phase } p$

$Ct_{max} = \text{base cycle} - \text{time}$

When one of the phases has either a shorter green-time than the minimum green-time or a longer green-time than the maximum green-time, the base cycle-time is calculated again with new variables; the variable is extended with the total minimum green-time and maximum green-time used and the variable is reduced by the load/capacity ratio of those phases which have either a minimum green-time or a maximum green-time:

$$t_{tl,new} = t_{tl} + t_{gt_{min}} + t_{gt_{max}}$$

$$Y_{t,new} = Y_t - Y_{gt_{min}} - Y_{gt_{max}}$$

With:

$t_{tl,new} = \text{new total lost time}$

$t_{gt_{min}} = \text{total time spent on minimum green} - \text{time}$

$t_{gt_{max}} = \text{total time spent on maximum green} - \text{time}$

$Y_{t,new} = \text{new load/capacity ratio}$

$Y_{gt_{min}} = \text{total load/capacity of minimum green} - \text{time}$

$Y_{gt_{max}} = \text{total load/capacity of maximum green} - \text{time}$

The cycle-times of the different maximum conflict groups can now be compared and the group with the highest cycle-time is the normative maximum conflict group. When multiple groups have the same maximal cycle-time, the group with the highest saturation degree is the normative maximum conflict group.

The green-times have to be calculated again for those phases that have neither minimum nor maximum green-time.

$$gt_{p,new} = \frac{Y_p}{Y_{t,new}} (Ct_{new} - t_{tl,new})$$

With:

$gt_{p,new} = \text{adjusted green} - \text{time for 'normal' phases}$

$Ct_{new} = \text{new cycle} - \text{time}$

The cycle-time and all green-times are known now and the saturation degree can be computed. This is done in the following way:

$$S_{deg,p} = Y_p \frac{Ct}{gt_{p,new}}$$

With:

$s_{deg,p}$  = saturation degree of phase  $p$

$$Ct = \begin{cases} Ct_{max} \rightarrow \text{all green} - \text{times are between min and max} \\ Ct_{new} \rightarrow \text{some green} - \text{times are not between min and max} \end{cases}$$

For all lane groups not in the normative conflict group, their green-times are calculated:

$$gt_p = \min \left( gt_{max}, \max \left( gt_{min}, Y_p \frac{Ct}{s_{deg,max}} \right) \right)$$

With:

$$s_{deg,max} = \max_p (s_{deg,p})$$

The green-times of the lanes are the same as the green-times of the phases or lane groups they are. With the green-times of the lanes and the cycle-time known, the calculation of the capacity per lane is simply a weighted average:

$$Q_l = \frac{gt_{l \in p}}{Ct} Q_{b,l}$$

With:

$Q_l$  = capacity of lane  $l$

$Q_{b,l}$  = base capacity of lane group  $l$

$gt_{l \in p}$  = green – time of lane  $l$  on phase  $p$

$Ct$  = cycle – time

The saturation degree of the lanes is calculated by means of:

$$s_{deg,l} = \frac{l_l}{Q_l}$$

With:

$s_{deg,l}$  = saturation degree of lane  $l$

$l_l$  = load of lane  $l$

For turns, the saturation degree is:

$$s_{deg,t} = \frac{\sum_{l \in \text{lanes}} l_{t \in l} \times s_{deg,l}}{\sum_{l \in \text{lanes}} l_{t \in l}}$$

With:

$s_{deg,t}$  = saturation degree of turn  $t$

$l_{l \in l}$  = load of turn  $t$  on lane  $l$

The capacity of the turns can now be calculated as follows:

$$Q_t = \frac{\sum_{l \in \text{lanes}} l_{t \in l}}{s_{deg,t}}$$

With:

$Q_t = \text{capacity of turn}$

### A.3.1 Delay calculation

The calculation of the average delay uses three parameters, these are load, capacity and green time. The calculation of the delay is given in the next equation:

$$D_l = \min (d_{1,l} + d_{2,l} + d_{3,l}, d_{max,l})$$

With:

$D_l = \text{Average delay on lane } l$

$d_{1,l} = \text{Uniform delay on lane } l$

$d_{2,l} = \text{Incremental delay on lane } l$

$d_{3,l} = \text{Geometric delay on lane } l$

$d_{max,l} = \text{Maximum delay on lane } l$

The uniform delay is calculated in the way of:

$$d_{1,l} = 0.5Ct \frac{(1 - \frac{gt_l}{Ct})^2}{(1 - (\min(1, \frac{l_l}{Q_l})) \frac{gt_l}{Ct})}$$

With:

$Ct = \text{cycle time}$

$gt_l = \text{green time of lane } l$

$l_l = \text{load on lane } l$

$Q_l = \text{capacity of lane } l$

The incremental delay is calculated in the way of:

$$d_{2,l} = \begin{cases} 900T(Y_l)^N \left[ (Y_l - 1) + \sqrt{(Y_l - 1)^2 + \frac{MK(Y_l - Y_0)}{Q_l T}} \right] \rightarrow Y_l > Y_0 \\ 0 \rightarrow Y_l \leq Y_0 \end{cases}$$

With:

$T = \text{duration of the project}$

$$Y_l = \frac{l_l}{Q_l}$$

$$Y_0 = 0.5 + b \times s_{sec,l} \times t_C$$

$$s_{sec,l} = \frac{Q_l}{3600}$$

The calculation of the geometric delay is calculated as follows:

$$d_{3,l} = dp(1 - fth_l) + fth_l$$

With:

$$fth_l = \frac{l_{th}}{l_{lt} + l_{th} + l_{rt}}$$

$l_l$  = load on lane  $l$

$l_{lt}$  = load of left turn movements

$l_{th}$  = load of through movements

$l_{rt}$  = load of right turn movements

As mentioned in the introduction, the delay in a dynamic situation only includes the incremental delay. In that case the uniform and geometric delays are set to 0.

#### **A.4 Delay calculation for an un-signalized roundabout**

The calculation of the capacity is done by lane group. In the case of an un-signalized roundabout, each branch will be treated as a lane group. This means for a normal (4-way) un-signalized roundabout, the number of lane groups is 4.

The calculation of the capacity is divided into two parts. The first part calculates the capacity per lane group.

In the second part, the volume/capacity ratio of each lane group which has to give way is taken into account.

The calculation of the capacity uses the loads of the lane groups. Because now the lane group is the complete branch, the loads of all turns of a branch have to be summed. These loads are computed by means of:

$$l_{lg} = \sum_{turn \ t \in lane\text{-}group \ lg} l_t$$

With:

$l_{lg}$  = load of the lane group  $lg$

$l_t$  = load of turn  $t$

##### **A.4.1 Capacity calculation - part 1**

The capacity is calculated using the following equation:

$$Q_{b,lg} = \max\left(\frac{1}{y} \partial (S_{lg} - 0.99(\alpha l_{AC} + \beta l_c)), Q_{min}\right)$$

$$s_{lg} = \frac{\sum_{turn \in lg} s_{b,t}}{nr_{t,lg}}$$

$$l_{AC} = \sum_{lg \in AC_{lg}} l_{lg}$$

$$l_c = \sum_{lg \in C_{lg}} l_{lg}$$

With:

$Q_{b,lg}$  = base capacity of lane group  $lg$

$Q_{min}$  = minimal capacity

$s_{lg}$  = saturation flow of lane group  $lg$

$l_{AC}$  = load of the apparent – conflict movements

$l_c$  = load of the conflict movements

$l_{lg}$  = load of lane group

$AC_{lg}$  = set of lane groups that have an apparent – conflict with lane group  $lg$

$C_{lg}$  = set of lane groups that have a conflict with lane group  $lg$

The values of the parameters  $\alpha$ ,  $\beta$  and  $\gamma$  are calculated as follows:

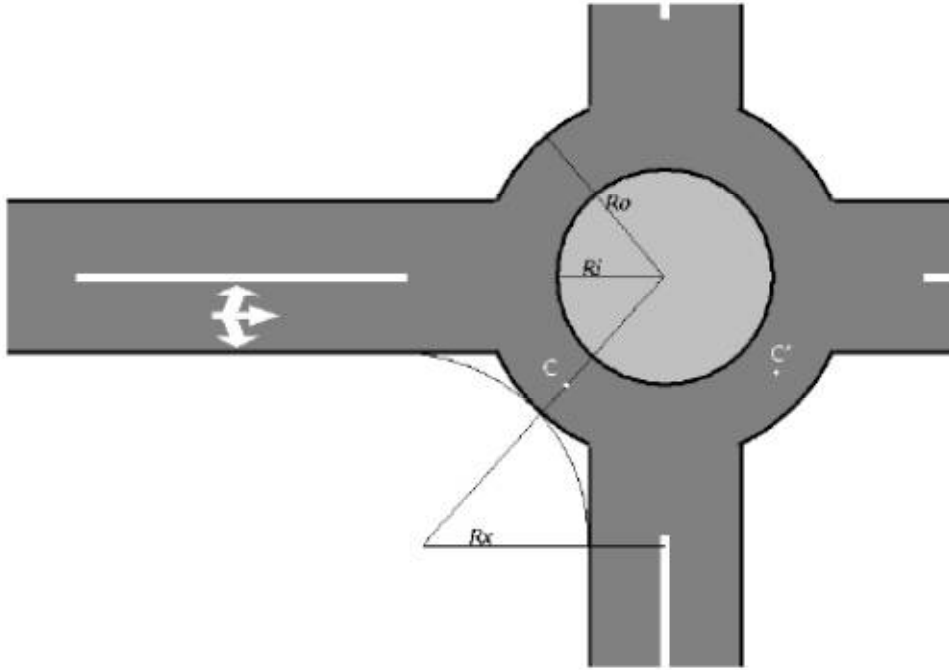
$$\alpha = \alpha_b \left( 1 + \frac{1}{3} - \frac{2}{3} \sqrt{\frac{l_{AC}}{s_b} \frac{l_{AC}}{l_{AC} + l_c}} \right)$$

$$\beta = \begin{cases} 1 & \rightarrow 1 \text{ lane roundabout} \\ 0.7 & \rightarrow 2 \text{ or more lanes roundabout} \end{cases}$$

$$\gamma = \begin{cases} 1 & \rightarrow \text{else} \\ 0.65 & \rightarrow 2 \text{ or more entry lanes and 2 or more lanes roundabout} \end{cases}$$

Parameter  $\alpha_b$  depends on the distance between points C and C' over the roundabout (see Figure 20).





**Figure 20: definition of radius in roundabouts (Bezembinder & Brandt, 2013)**

The calculation of the distance between point C and C' is the following:

$$d_{c,c'} = \begin{cases} R_{c,c'}(\angle_x + \angle_e) \rightarrow \text{if } \angle_x \text{ and } \angle_e \text{ exist} \\ 0 \rightarrow \text{else} \end{cases}$$

Where

$$R_{c,c'} = \frac{R_i + R_o}{2}$$

$$\angle_e = \arcsin\left(\frac{R_e + nr_{l,e} \times w_{l,e} + \frac{W_m}{2}}{R_e + R_o}\right)$$

$$\angle_x = \arcsin\left(\frac{R_x + nr_{l,e} \times w_{l,e} + \frac{W_m}{2}}{R_x + R_o}\right)$$

Where

$$R_o = R_i + nr_{l,ra} \times w_{l,ra}$$

With:

$d_{c,c'}$  = distance over the roundabout between points C and C'

$R_i$  = radius of circle inside the lanes of the roundabout

$R_o$  = radius of circle with the lanes of the roundabout

$R_e$  = radius of the entire circle

$R_x$  = radius of the exit circle

$nr_{l,e}$  = number of entry lanes

$nr_{l,x}$  = number of exit lanes

$nr_{l,ra}$  = number of lanes on roundabout

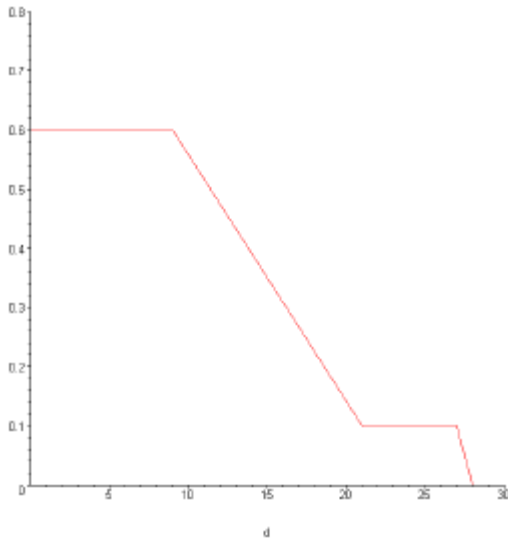
$w_{l,e}$  = width of entry lanes

$w_{l,x}$  = width of exit lanes

$w_{l,ra}$  = width of lanes on roundabout

$w_m$  = width of median

Part of the circle with radius  $R_x$  is drawn in Figure 20. The circle with radius  $R_e$  lies on the other side of the branch and it has another value. The way  $\alpha_b$  depends on  $d_{c,c'}$  is depicted in the following graph with  $\alpha_b$  on the vertical axis (Figure 21).



**Figure 21: relation between  $\alpha_b$  and  $d_{c,c'}$**

In mathematical notation this becomes:

$$\alpha_b = \begin{cases} 0.6 \rightarrow 0 < d_{c,c'} < 9 \\ \frac{23.4 - d_{c,c'}}{24} \rightarrow 9 < d_{c,c'} < 21 \\ 0.1 \rightarrow 21 < d_{c,c'} < 27 \\ \frac{28 - d_{c,c'}}{10} \rightarrow 27 < d_{c,c'} < 28 \\ 0 \rightarrow 28 < d_{c,c'} \end{cases}$$

In the calculation of  $\alpha$ , it is possible to have an apparent conflict load of 0 and a conflict load of 0, this gives a division by zero. In this case the limit goes to zero so  $\alpha = 4/3\alpha_b$ .

#### **A.4.2 Capacity calculation - part 2**

Now, based on the calculated capacities, the V/C- ratios can be calculated (only for the lane groups who have to give way are interesting). If one of these ratios exceeds 1.0 (an oversaturated situation), all capacities will be calculated again (part 1), where all loads will be adjusted:

$$Q_{lg} = \begin{cases} Q_{b,lg} \rightarrow \frac{l_{lg}}{Q_{b,lg}} \leq 1 \\ Q_{b,new} \rightarrow \frac{l_{lg}}{Q_{b,lg}} > 1 \end{cases}$$

With

$Q_{lg}$  = capacity of lane group  $lg$

$Q_{b,lg}$  = base capacity of lane group  $lg$

$Q_{b,new}$  = new calculation of  $Q_{b,lg}$  with  $l_{lg,new}$

$$l_{t,new} = \begin{cases} \frac{s_{lg}}{\gamma \times l_{lg}} \rightarrow l_{lg} > \frac{s_{lg}}{\gamma} \\ \frac{19}{20} l_t \rightarrow Q_{b,lg} < l_{lg} \leq \frac{s_{lg}}{\gamma} \end{cases}$$

The calculation of the average delay uses two parameters. These are load and capacity and are both needed on lane level. The converting of capacity from lane group to capacity of lane is as follows:

$$Q_l = \begin{cases} \frac{l_t}{l_{lg}} Q_{lg} \rightarrow l_t > 0 \\ \frac{Q_{lg}}{nr_{l,lg}} \rightarrow l_t = 0 \end{cases}$$

With:

$Q_l$  = capacity of lane  $l$

$Q_{b,l}$  = base capacity of lane group  $l$

$l_l$  = load on lane  $l$

$l_{lg}$  = load on lane group  $lg$

$nr_{l,lg}$  = number of lanes  $l$  on a lane group  $lg$

### A.4.3 Delay calculation

The calculation of the average delay uses two parameters, these are load and capacity. The calculation of the delay is given in the next equation:

$$D_l = \min (d_{1,l} + d_{2,l} + d_{3,l}, d_{max,l})$$

With:

$D_l$  = Average delay on lane  $l$

$d_{1,l}$  = Uniform delay on lane  $l$

$d_{2,l}$  = Incremental delay on lane  $l$

$d_{3,l}$  = Geometric delay on lane  $l$

$d_{max,l}$  = Maximum delay on lane  $l$

The uniform delay is calculated in the way of:

$$d_{1,l} = \frac{3600}{Ql}$$

With:

$Ql$  = capacity of lane  $l$

The incremental delay is calculated in the way of:

$$d_{2,l} = \begin{cases} 900T(Y_l)^N \left[ (Y_l - 1) + \sqrt{(Y_l - 1)^2 + \frac{MK(Y_l - Y_0)}{Q_l T}} \right] \rightarrow Y_l > Y_0 \\ 0 \rightarrow Y_l \leq Y_0 \end{cases}$$

With:

$T$  = duration of the project

$$Y_l = \frac{l_l}{Q_l}$$

$$Y_0 = 0.5$$

The calculation of the geometric delay is calculated as follows:

$$d_{3,l} = dp$$

The last step in the calculation of delay, the delay of the lane groups is calculated by means of:

$$D_{lg} = \begin{cases} \frac{\sum_{l \in \text{lanes}} (D_l \times l_l)}{l_{lg}} \rightarrow l_{lg} > 0 \\ \frac{\sum_{l \in \text{lanes}} D_l}{nr_{lg}} \rightarrow l_{lg} = 0 \end{cases}$$

With:

$D_l$  = average delay of lane group  $lg$

$nr_{l,lg}$  = number of lanes  $l$  on lane group  $lg$

As mentioned in the introduction, the delay in a dynamic situation only includes the incremental delay. In that case the uniform and geometric delays are set to 0.

## B Appendix: Junction designs

The numbers in the captions of the junction designs represent the number which is used in the further analysis. It is built up on the main junction type: 1 = equal junction, 2 = priority junction, 3 = signalized junction and 4 = roundabout and the following number within that main junction type.

### B.1 Equal junctions

The equal junction has two types that are evaluated. These types have single entry lanes and single exit lanes for all directions. Double lanes on an equal junction are not considered. The two types of an equal junction differ in the dimension of the mid-verge of five metres on the main direction. The two options are with and without a mid-verge. With a mid-verge one vehicle can stand in the middle of the junction to cross it in two times. This mid-verge dimension is selected on the main direction of the traffic stream that will go straight ahead. The two equal junctions evaluated in this research are showed in Figure 22 and Figure 23.

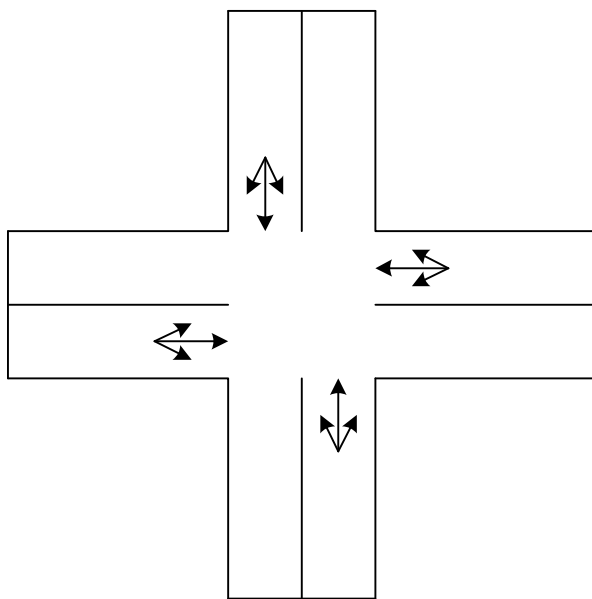


Figure 22: 101 equal junction

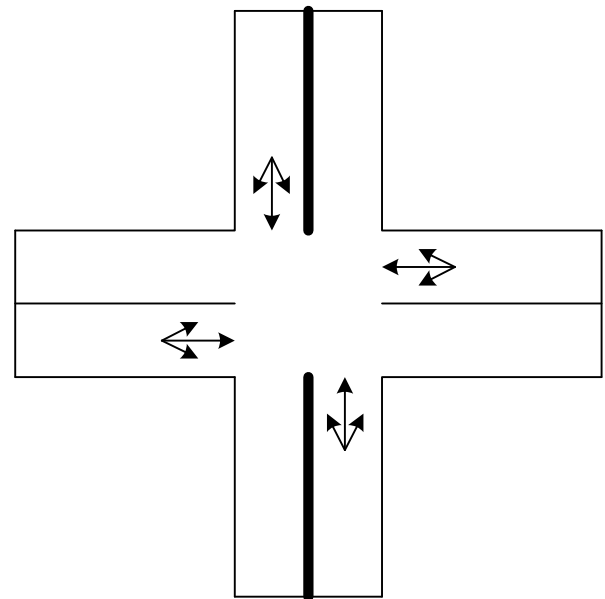


Figure 23: 102 equal junction with mid-verge on main direction

### B.2 Priority junctions

Four types of priority junctions are evaluated. A priority design related to the main stream that goes straight ahead is evaluated with and without a mid-verge of five metres (Figure 24 and Figure 25). Furthermore, a priority design that has a turn on the main stream is evaluated with and without a mid-verge of five metres (Figure 26 and Figure 27).

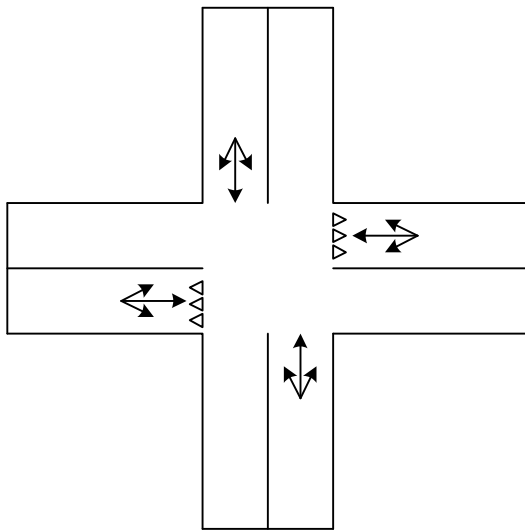


Figure 24: 201 priority junction main direction straight ahead

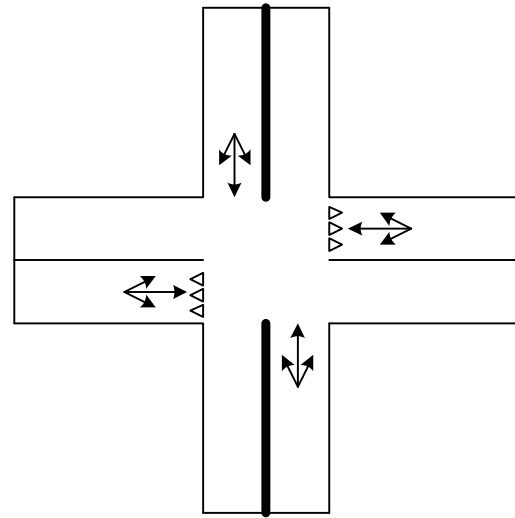


Figure 25: 202 priority junction with mid-verge main direction straight ahead

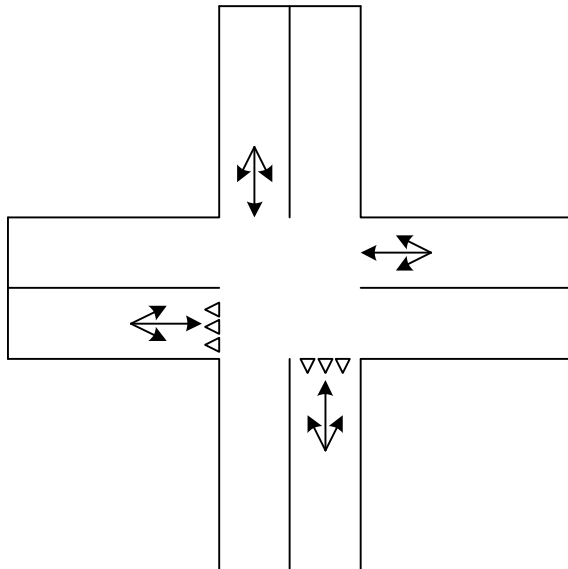


Figure 26: 203 priority junction main direction turn

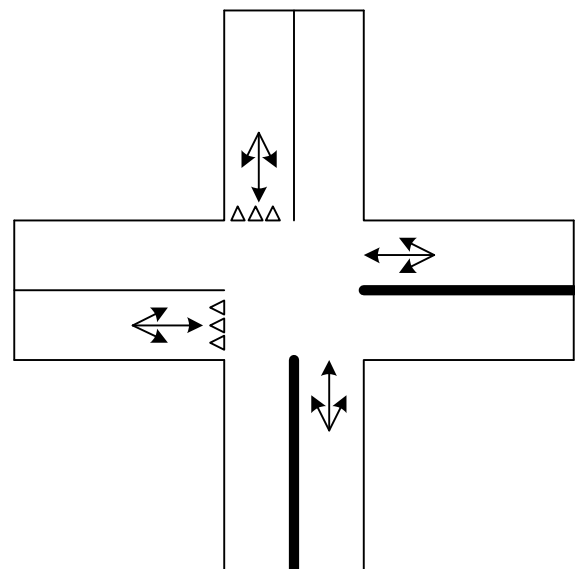


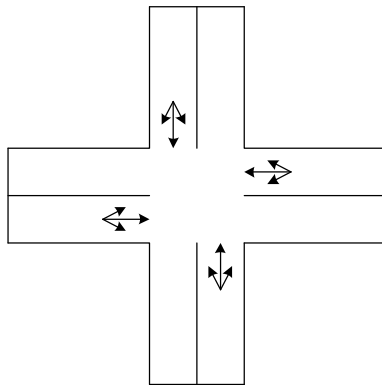
Figure 27: 204 priority junction with mid-verge main direction turn

### B.3 Signalized junctions

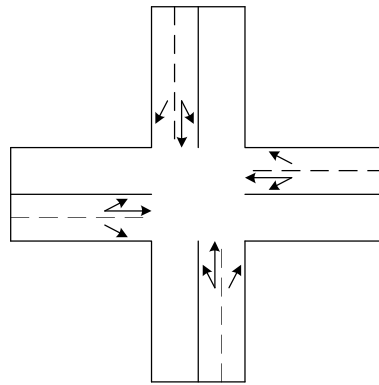
The signalling scheme is, not within the scope of this research. Therefore a signalling scheme that is available in the junction module is used. This signalling scheme is: the automated control type in which the junction module calculates an optimal (minimum average control delay) cycle time and green times.

The approach lane configuration is varied regarding the four main directions: all equal, straight ahead, turn and one direction. Furthermore, one or two exit lanes are used. This is dependent on the number of approach lanes that enter the exit lane at the same time. The last split is between smaller junctions (with one combined approach lane for all directions) to large junctions (with two approach lanes for one direction).

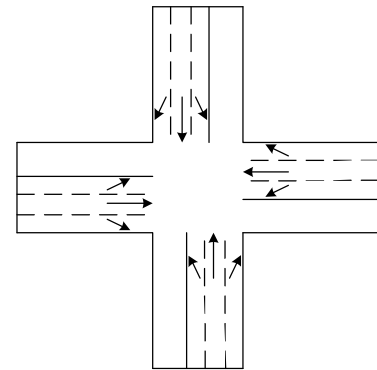
The junctions with all equal traffic flows and single exit lanes are shown in Figure 28, Figure 29 and Figure 30.



**Figure 28: 301 signalized junction equal traffic streams single approach lane**

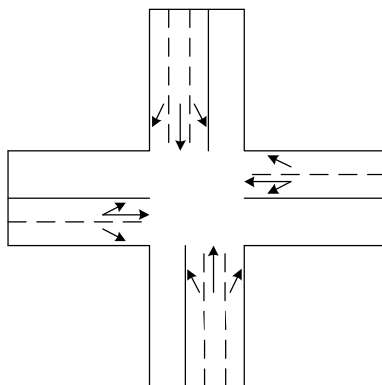


**Figure 29: 302 signalized junction equal traffic streams double approach lanes**

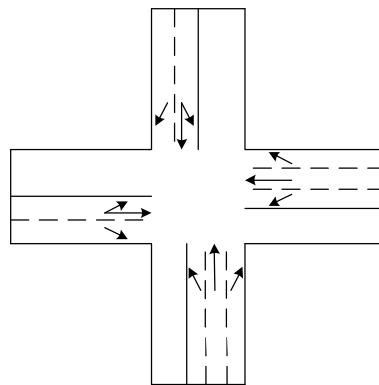


**Figure 30: 303 signalized junction equal traffic streams triple approach lanes**

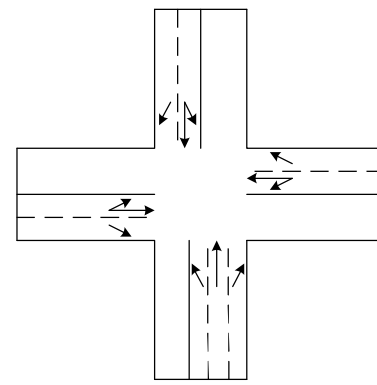
The junction with the main stream straight ahead is shown in Figure 31. The junction with the main stream in a turn is shown in Figure 32. The junction with one single main direction is shown in Figure 33. All these designs have single exit lanes.



**Figure 31: 304 signalized junction main stream straight ahead**

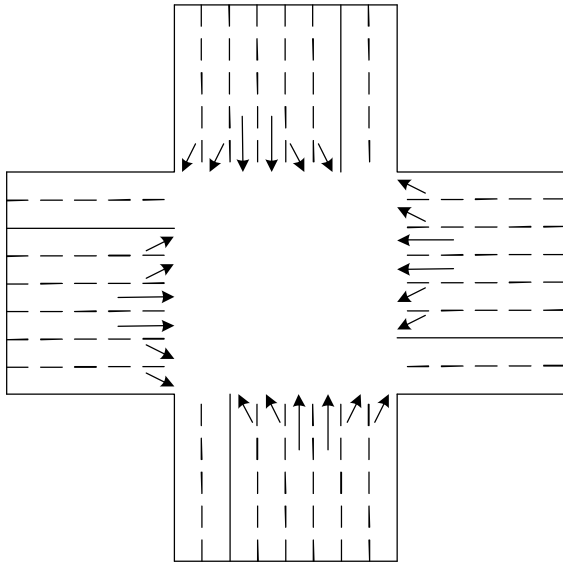


**Figure 32: 305 signalized junction main stream turn**

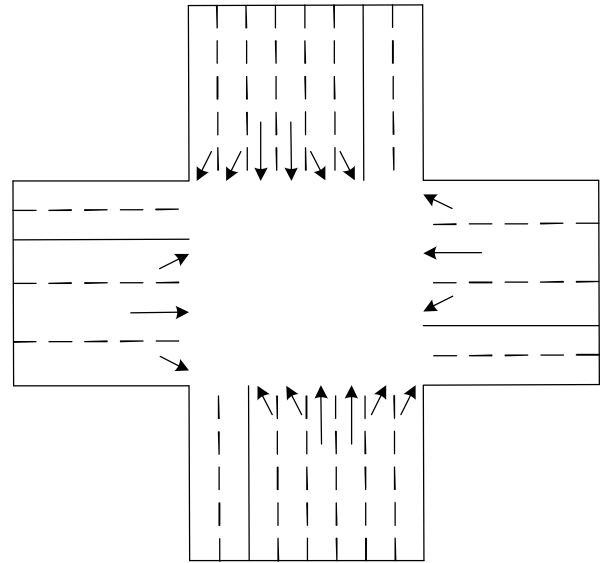


**Figure 33: 306 signalized junction main stream one direction**

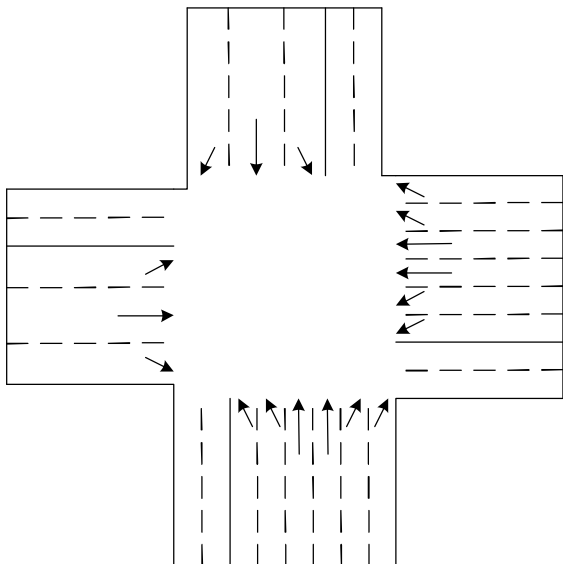
In the next junction designs all directions have double exit lanes. The first junction design shows a junction with all equal traffic streams (Figure 34). Figure 35 shows a junction design with the main stream straight ahead while Figure 36 shows a junction design with the main stream in a turn. At last, Figure 37 shows one main direction.



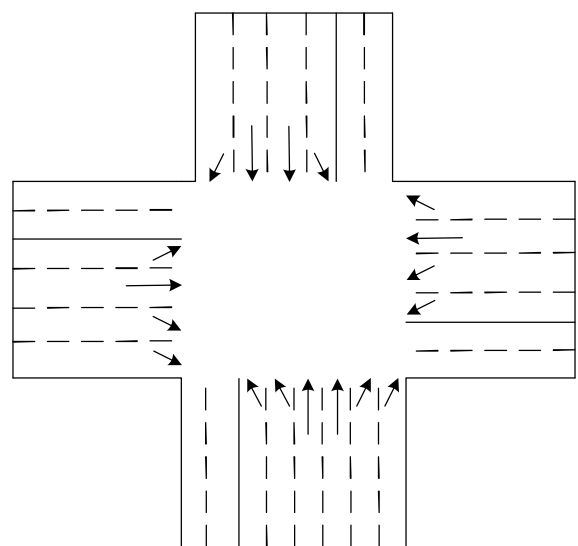
**Figure 34: 307 signaled junction all equal traffic streams double exit lanes**



**Figure 35: 308 signaled junction main stream straight ahead double exit lanes**



**Figure 36: 309 signaled junction main stream turn double exit lanes**



**Figure 37: 310 signaled junction main stream one direction double exit lanes**



### B.4 Roundabouts

For roundabouts two options are evaluated: single lane roundabouts and double lane roundabouts. For double lane roundabouts also two approach lanes are apparent. One for the right turn combined with the straight ahead direction and another for the left turn combined with the straight ahead direction. The traffic on the roundabout has priority over the entering traffic. This prevents that the traffic on the roundabout blocks other directions because they cannot exit the roundabout. Figure 38 and Figure 39 show these roundabouts.

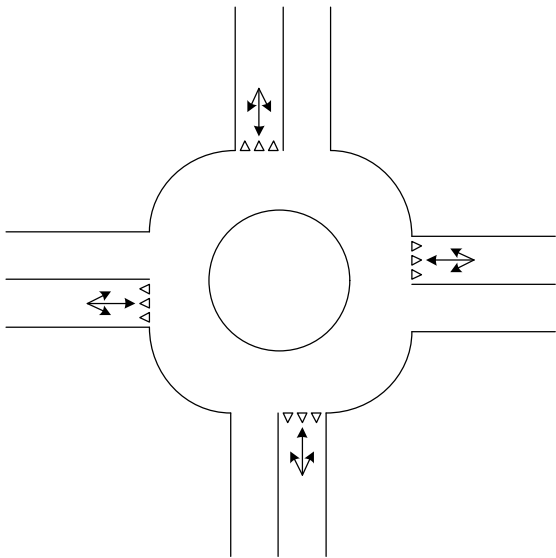


Figure 38: 401 single lane roundabout

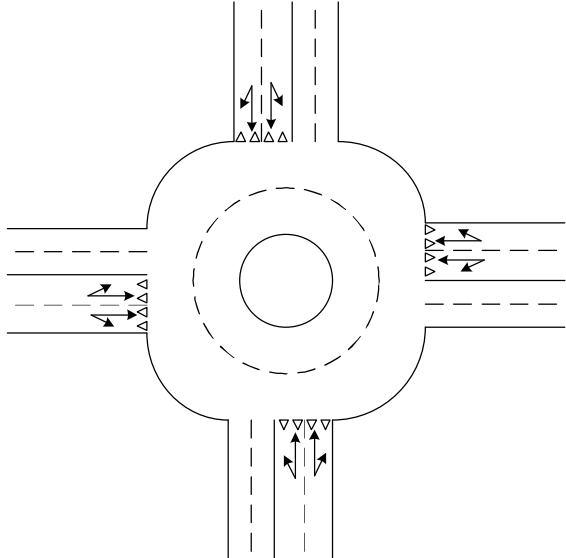


Figure 39: 402 double lane roundabout

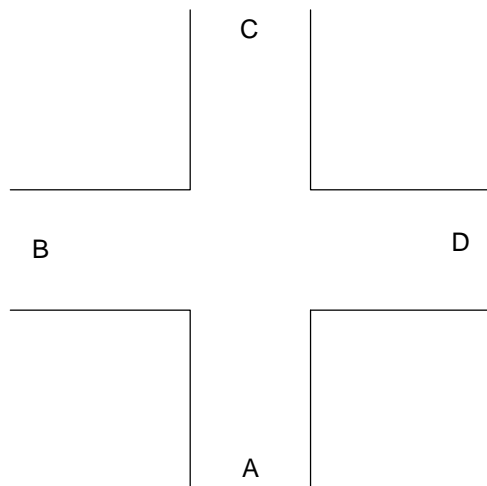
## C Appendix: Calculation procedure of exit rates

The demand patterns are calculated by the percentages that are coupled to the four junction directions. Four main streams of traffic are used to select the junction designs. For these four directions origin-destination matrices are made in which percentages of the flow will be showed. This O/D-matrix is based on the standard junction scheme in Figure 40. The percentages of total traffic that are coupled with the four main streams are showed in Table 22.

**Table 22: Total traffic coupled to junction direction**

Main stream	Direction A	Direction B	Direction C	Direction D
All equal	25%	25%	25%	25%
Straight ahead	40%	10%	40%	10%
Turn	40%	10%	10%	40%
One direction	70%	10%	10%	10%

This table is translated into an O/D-matrix which will be performed with the next procedure. For the main stream straight ahead the procedure is explained, the O/D-matrices of the other main streams are calculated in the same way.



**Figure 40: Standard junction scheme**

The percentages in Table 22 actually represent the production and attraction of the junction directions. To produce an O/D-matrix, these percentages are multiplied for every turn. For the turn A-B this means:  $40\% \times 10\% = 4\%$ . So 4% of the total traffic over the junction starts in A and travel to B. This action is performed for every turning direction, except of the returning directions (A-A, B-B, C-C and D-D). This leads to an O/D-matrix shown in Table 23.

**Table 23: Initial O/D-matrix for main stream straight ahead**

From	To	A	B	C	D
A		X	4%	16%	4%
B		4%	X	4%	1%
C		16%	4%	X	4%
D		4%	1%	4%	X

In this O/D-matrix the total of the percentages is 66%, while 100% crosses the junction. This is caused by the percentages that will return to their starting point. For example, the percentage from A to A will be  $40\% \times 40\% = 16\%$ . Adding these returning movements results in a total of 100%. These returning directions are not used and therefore the total of the initial O/D-matrix is translated to 100%. This is performed by dividing every turning percentage by the total percentage which, in this case, is 66%. For example, the new percentage of the turning direction A-B is:  $\frac{4\%}{66\%} = 6\%$ . This action is performed for every direction. The total of this matrix is 100%, this means that 100% of the traffic is assigned to one of the twelve directions. The O/D-matrices for the other main streams are calculated in the same way. All are presented in Table 24, Table 25, Table 26 and Table 27.

**Table 24: O/D-matrix for main stream straight ahead**

From	To	A	B	C	D
A		X	6%	24%	6%
B		6%	X	6%	2%
C		24%	6%	X	6%
D		6%	2%	6%	X

**Table 26: O/D-matrix main stream turn**

From	To	A	B	C	D
A		X	6%	6%	24%
B		6%	X	2%	6%
C		6%	2%	X	6%
D		24%	6%	6%	X

**Table 25: O/D-matrix main stream all equal**

From	To	A	B	C	D
A		X	8.3%	8.3%	8.3%
B		8.3%	X	8.3%	8.3%
C		8.3%	8.3%	X	8.3%
D		8.3%	8.3%	8.3%	X

**Table 27: O/D-matrix main stream one direction**

From	To	A	B	C	D
A		X	14.7%	14.7%	14.7%
B		14.7%	X	2%	2%
C		14.7%	2%	X	2%
D		14.7%	2%	2%	X

### C.1 Total traffic demand calculation example

The total traffic demand of 1500 vehicles per hour is applied to the main stream straight ahead (shown in Table 24). Every percentage is multiplied by 1500 and this leads to the O/D-matrix presented in Table 28: O/D-matrix for the main direction straight ahead in vehicles per hour.

**Table 28: O/D-matrix for the main direction straight ahead in vehicles per hour**

From	To	A	B	C	D
A		X	90	360	90
B		90	X	90	30
C		360	90	X	90
D		90	30	90	X

## D Appendix: Calculation average speed on dynamic junction

The average speed in the dynamic model is calculated per link part per time interval. To calculate the average speed on the total junction a weighted sum has to be used because when a link part in a certain time interval has the average speed of 30 km/h but no load. This average speed should not be part of the average speed calculation of the total junction. This is solved by weight the average speed on the link parts per time step according the load on that link part. The average speed per link part and time step is multiplied by the load per link part and time step. This is divided by the total load on all links and time steps. Summing all these values per link gives the average speed for the junction. The equation is:

$$s_j = \sum_l \frac{s_{l,t} \times V_{l,t}}{\sum_l \sum_t V_{l,t}}$$

With:

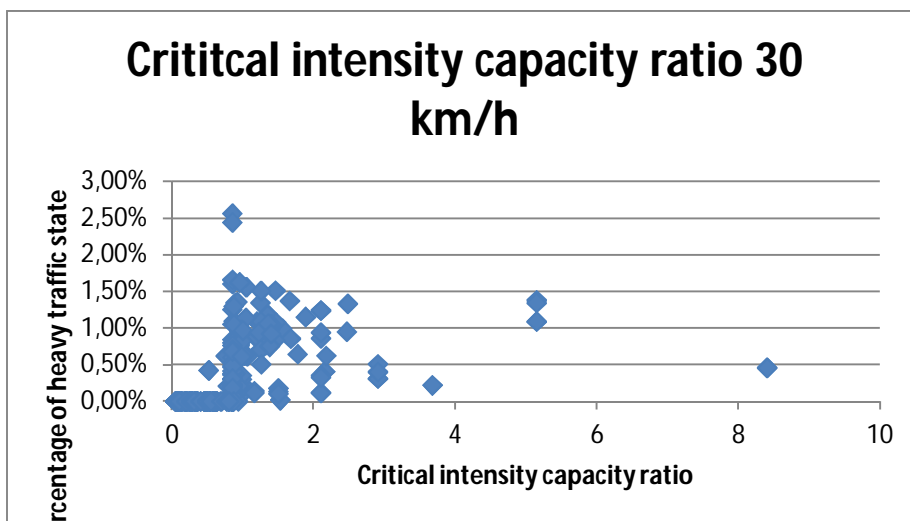
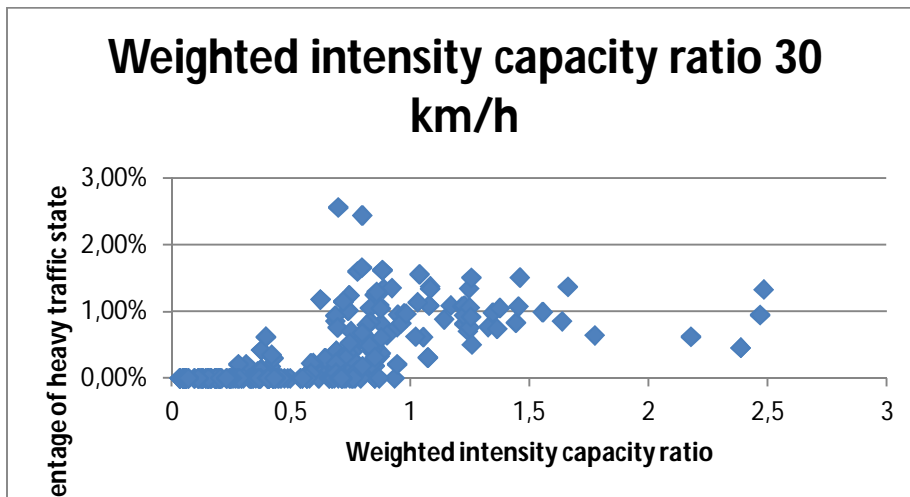
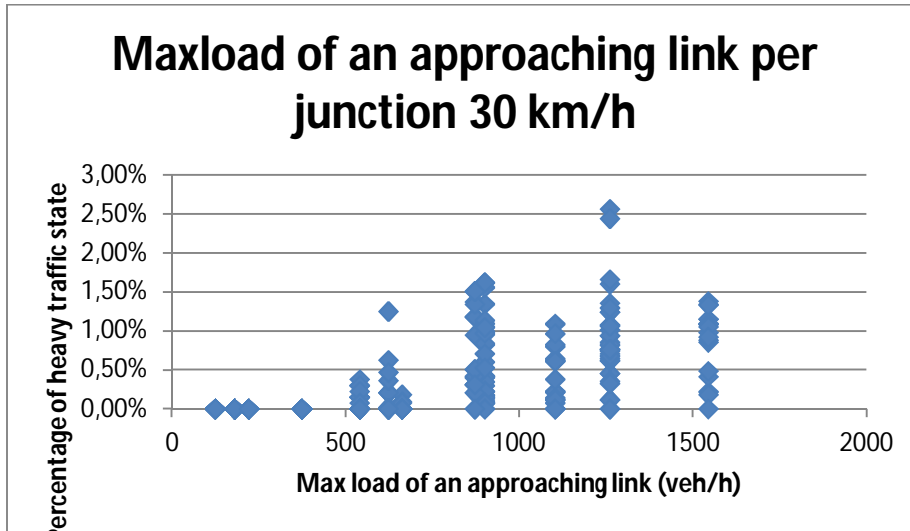
$s_j$  = average speed on junction  $j$

$s_{l,t}$  = average speed per link part  $l$  and time interval  $t$

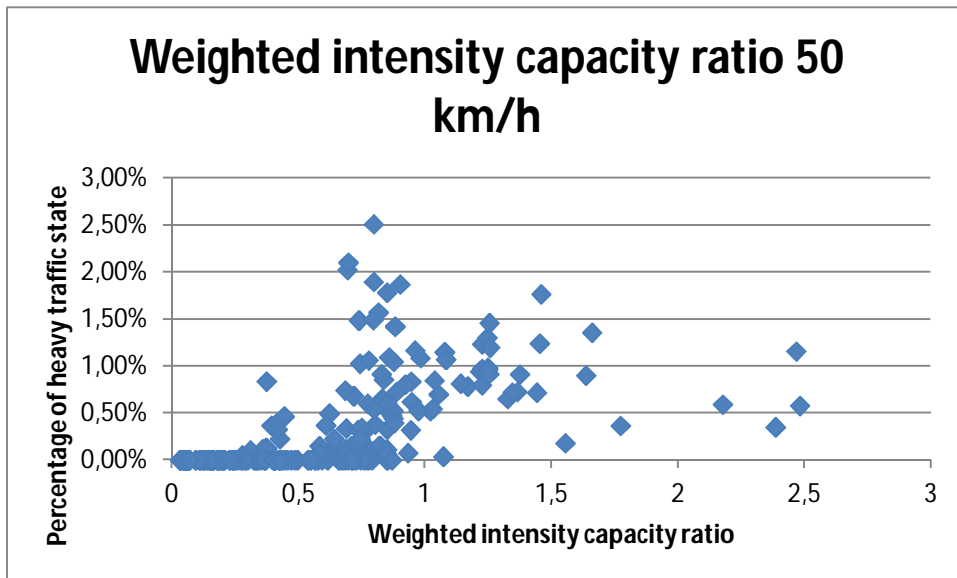
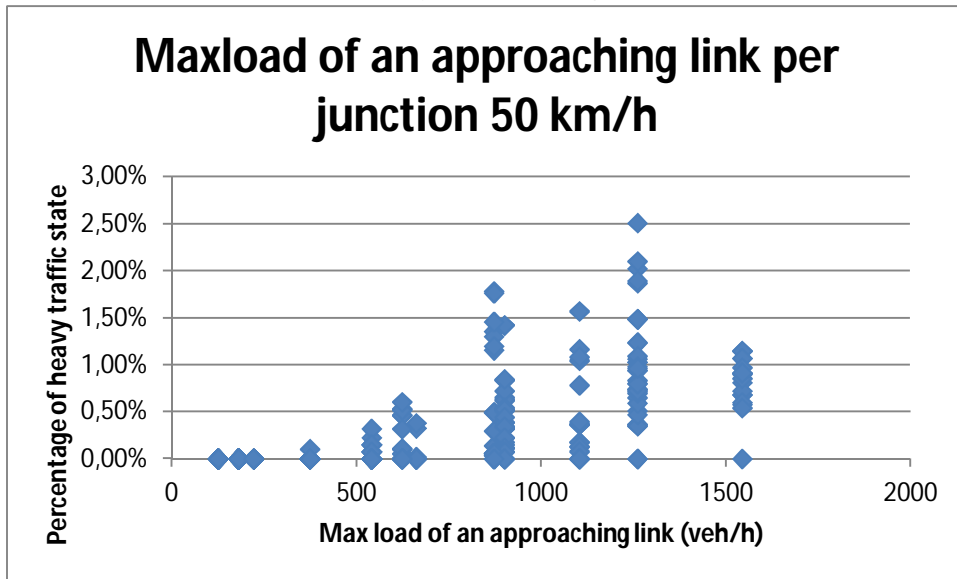
$V_{l,t}$  = load per link part  $l$  and time interval  $t$

## E Appendix: Scatter plots for heavy and saturated percentages

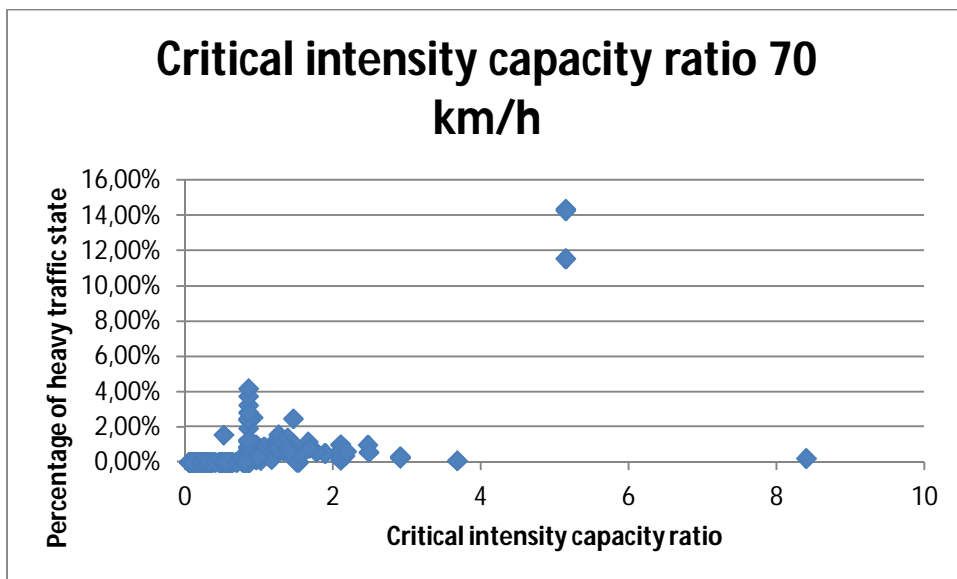
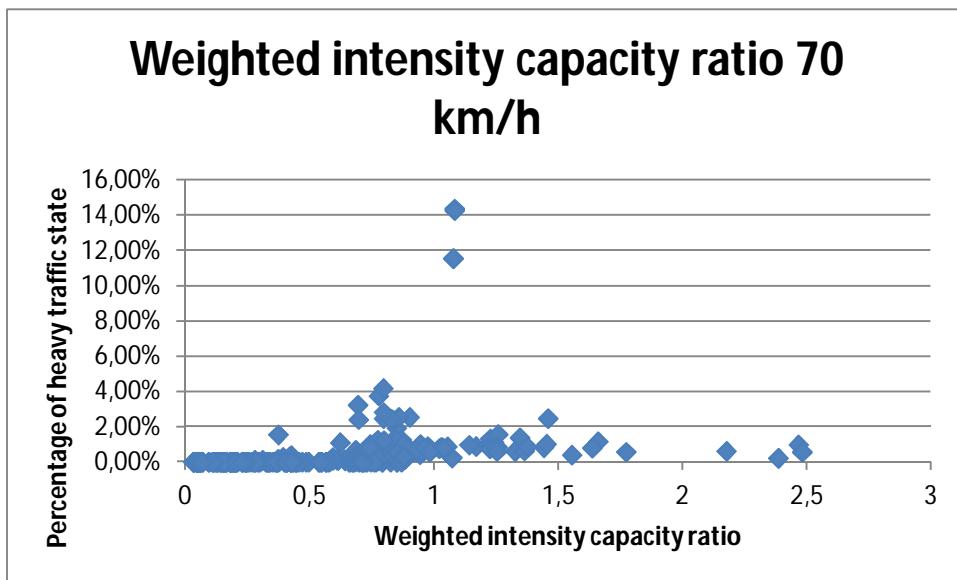
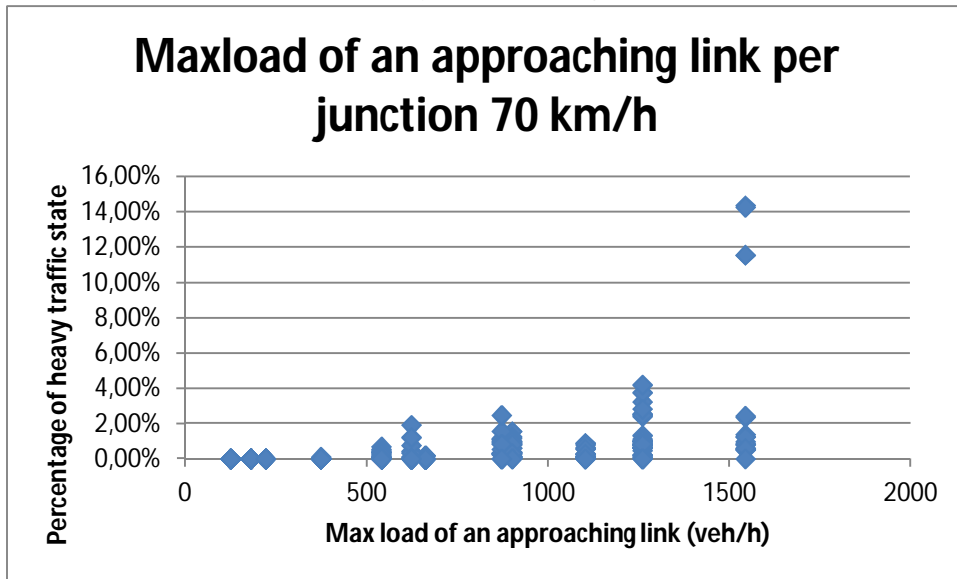
### E.1 Scatter plots for heavy percentages 30 km/h



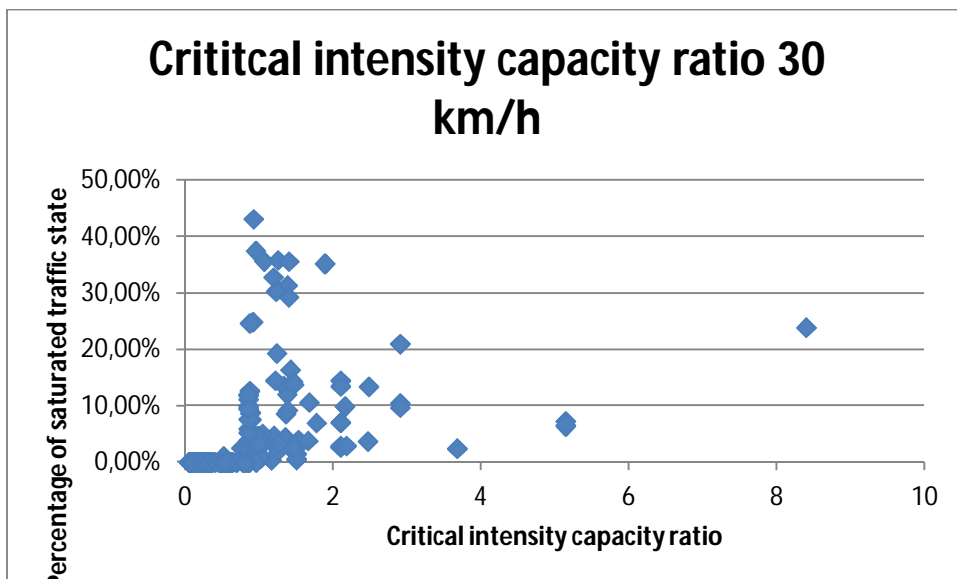
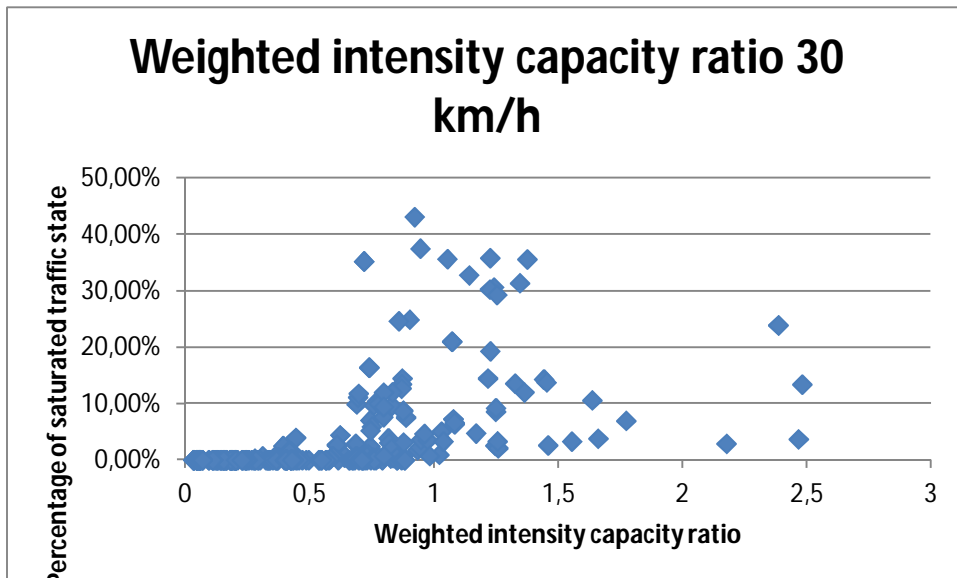
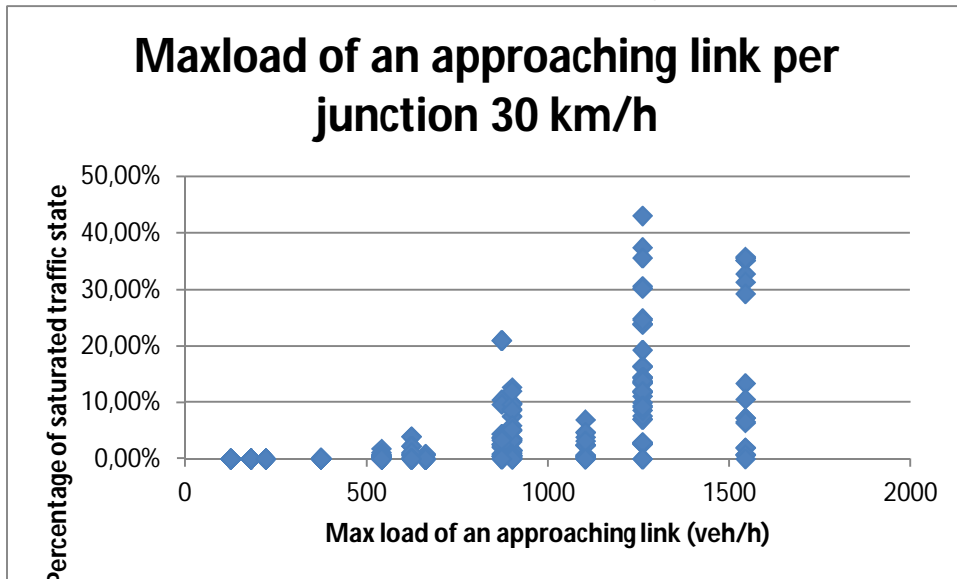
## E.2 Scatter plots for heavy percentages 50 km/h



### E.3 Scatter plots for heavy percentages 70 km/h

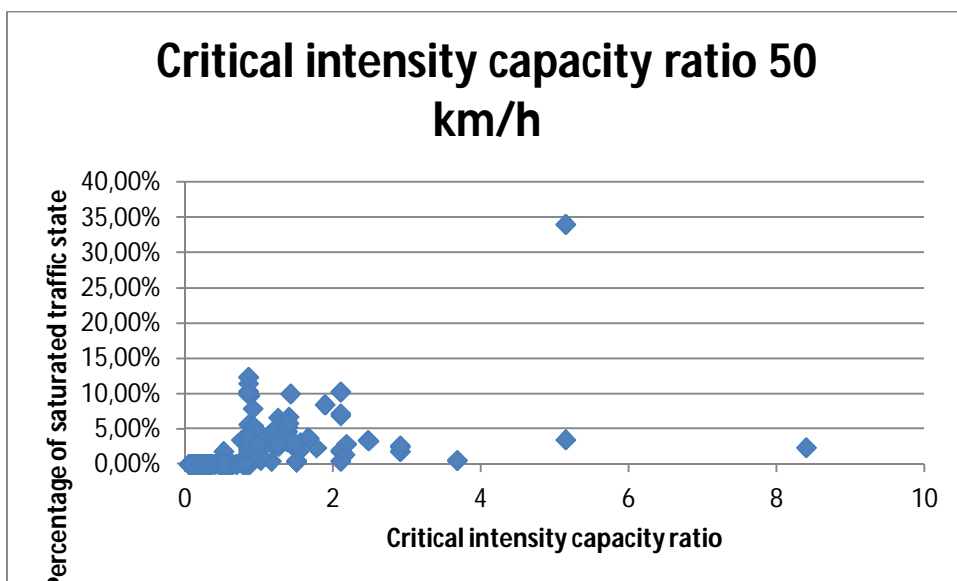
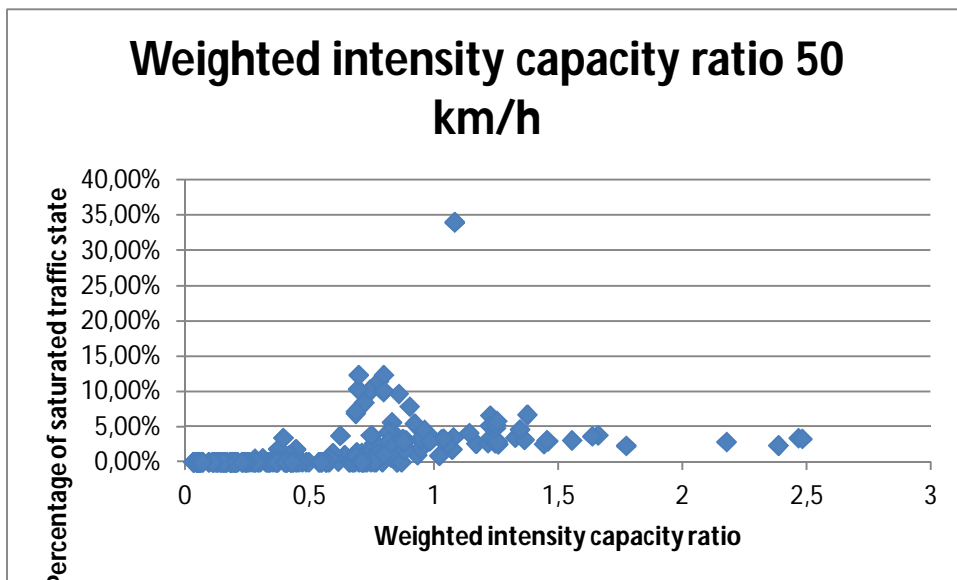
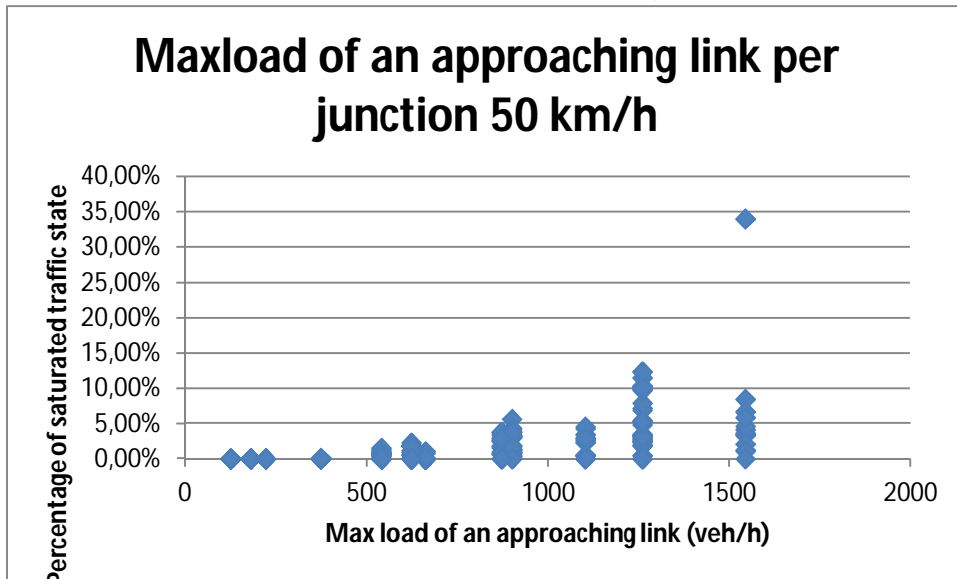


#### E.4 Scatter plots for saturated percentages 30 km/h





### E.5 Scatter plots for saturated percentages 50 km/h



**E.6 Scatter plots for saturated percentages 70 km/h**

